



## Manufacturer of Speedsharp Breaker Steel

### PRODUCT DISCOUNT

**A** \_\_\_\_\_

**B** \_\_\_\_\_

\*For tools 24" and longer, discounts may vary - please call for a price quote.

### TERMS & CONDITIONS

Champion Chisel Works Inc. tools are warranted against defects in material and workmanship. Adjustments will be made on any tool which does not perform to your satisfaction, provided it has not been abused during operation. No other warranty is implied or expressed in this catalog. Tools should be used for the purpose they were designed. Pneumatic and electric steel tools are designed and heat treated for use only in air and electric tool applications. Champion Chisel Works, Inc. strives to provide customers with competitive pricing for the current market. However, all prices are subject to change without notice.

### TABLE OF CONTENTS

Bit Sharpener	3
Pneumatic Chipper Steel	4 - 7
Pavement Breaker Steel	8 - 10
Tent Stake Drivers	10
Jumbo Rivet Buster Steel	11
Tampers	11
Floor Scrapers	12 - 13
Electric Chipper Steel	14 - 19
Pneumatic Zip Gun Bits	20
Pneumatic Weld Flux Bits	21
Boom Mounted Demolition Bits	22 - 25
Drill Steel & Rock Bits	26
Whirley Bits	27
Air Tool Accessories	28 - 29

### FREIGHT POLICY

All prices are FOB Shipping Point or prepay and add as follows:

\$100 - \$1,499 (net price)	Customer Pays Total Freight
\$1,500 - \$1,999 (net price)	Customer Pays 1/2 Freight
\$2,000 + (net price)	Freight Prepaid



## Safety Tips & Warnings

The following recommendations should help to increase the life of the tool and also contribute to personal safety and better performance.

- When using any tool, safety glasses, safety shoes, safety helmet, safety gloves and ear plugs should be worn for full protection.
- Always have a sure footing to give hammer proper support while operating and don't take chances.
- Never use air tools for prying during use. If tool is being used properly, this action is not necessary.
- Never use dull tools as they will accomplish very little and could break from fatigue. Proper reconditioning procedures should be followed to prevent premature breakage.
- Hammer parts should always be kept in good repair. Worn bushings and pistons cause excessive shank wear on tools.
- Warm tools prior to use when temperature is below freezing.
- Warranty applies only to tools in their original condition. Reconditioned tools are not covered by warranty except when reconditioning is done by Champion Chisel Works Inc.

# SHANK REFERENCE

## PNEUMATIC CHIPPER STEEL (p.4-7)

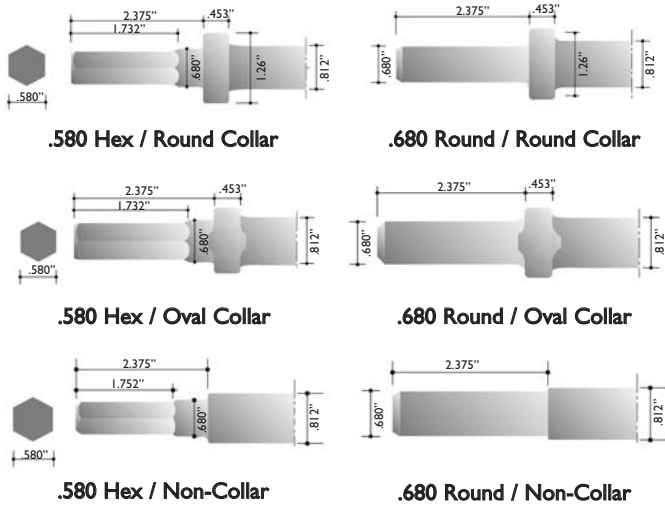

## ELECTRIC CHIPPER STEEL (p. 14-19)

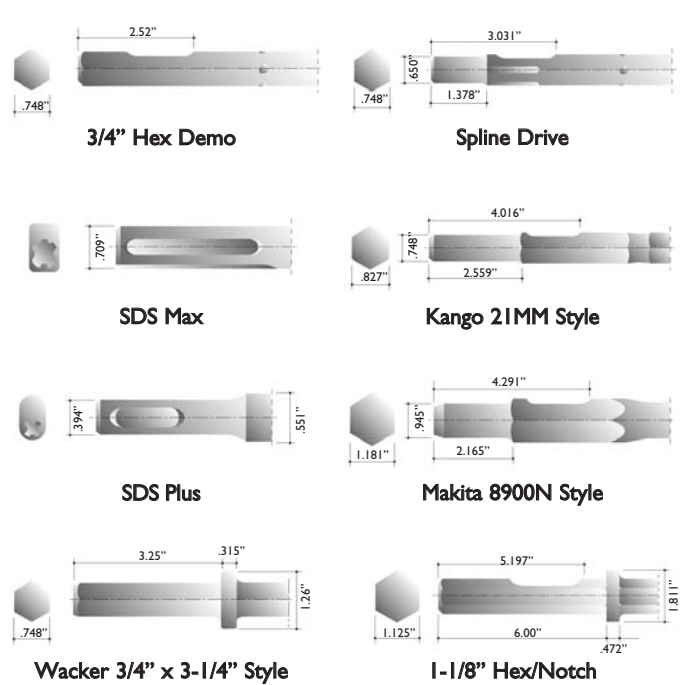

## PAVEMENT BREAKER STEEL (p. 8-10)

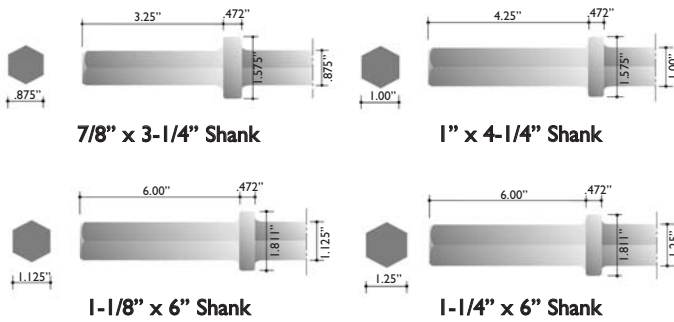

## RIVET BUSTER (p. 11)

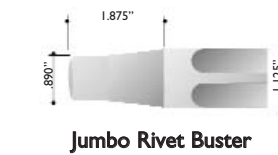

Additional electric shanks included on pages 12-19:

- Hilti 805/905 Style
- Makita HK1810 Style
- Edco .590\"/>
- Edco 7/8\"/>

## PNEUMATIC ZIP GUN BITS (p.20)

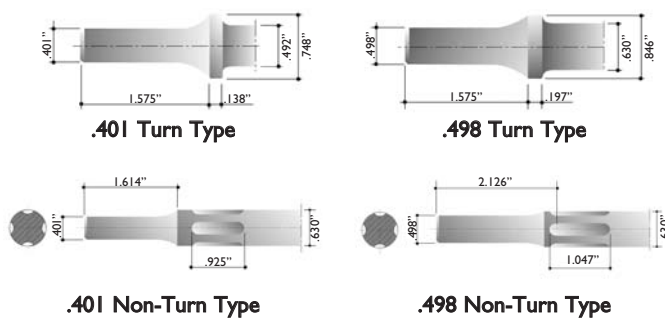

## WELD FLUX SCALING BITS (p.21)

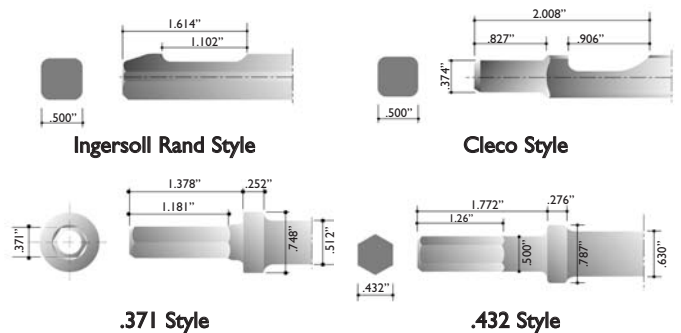

# SPEEDSHARP BREAKER STEEL

- TOUGH, ABRASION RESISTANT ALLOY STEEL
- DESIGNED FOR SPEEDSHARPENING OR FORGING
- LONGER LASTING IN ALL CONDITIONS

Now you can have breaker tools made from modern alloy steel that is superior - in every respect - to the 19th century carbon steel designed for sharpening by reforging used by other manufacturers. After years of field use, under the most grueling conditions, Speedsharp Breaker Steel has proven it can benefit anyone using breaker tools, regardless of location, conditions, or method of resharpening.

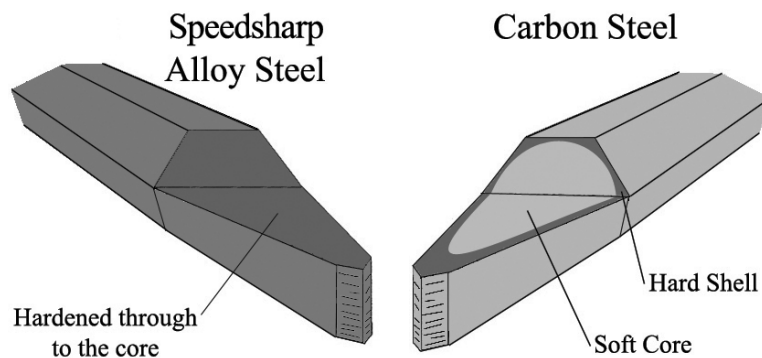

Sharpening the chisel reduces the hard shell of Carbon Steel chisels.

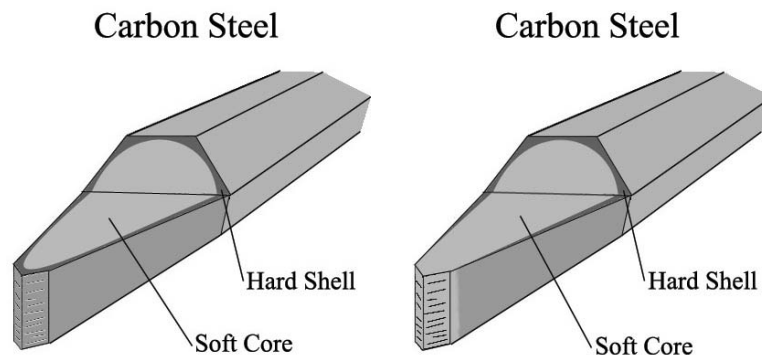

Repeated sharpening of the chisel leaves the soft core fully exposed which can lead to mushroomed or bent tips.

# BIT SHARPENER

- Sharpen Breaker Steel moil points and chisels, dress asphalt cutters, clay spades and wide chisels for the life of the tools.
- Grinds and dresses steel and other metal parts quickly and effectively.

Description	Unit Price
Grindsharp Bit Sharpener (Delivered)	1,186.50
Abrasive Belt 6"x48"- 24 Grit	19.11

The Grindsharp Bit Sharpener uses an aggressive 6" x 48" abrasive belt to quickly remove material and a rubber contact wheel which is necessary when grinding hard materials, such as steel and other metals. A strong one horsepower 120 volt motor allows full pressure to be applied so metal is quickly removed before heat can build up in the steel.

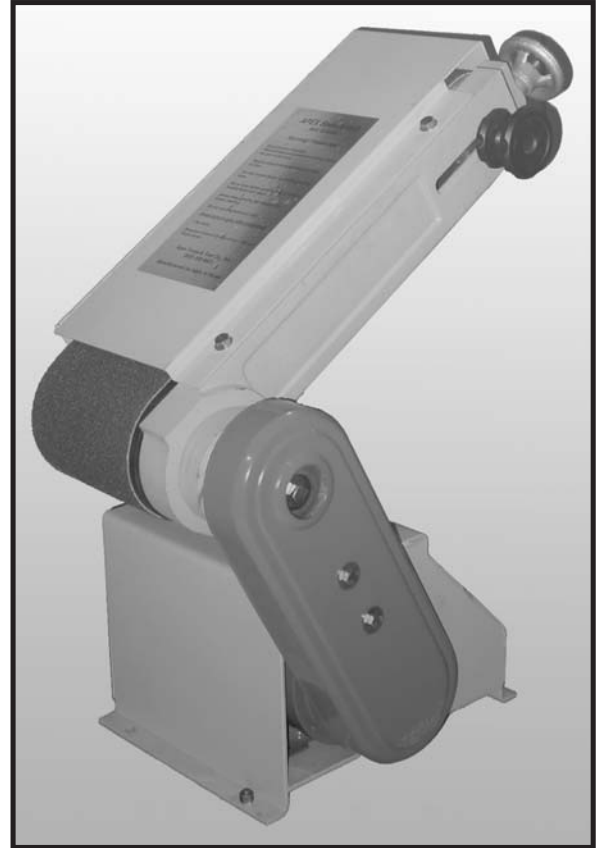

**ONLY 30 SECONDS  
TO NEW POINTS.**



**BEFORE**



**AFTER**



(A)

# TOOL BITS FOR PNEUMATIC CHIPPING HAMMERS

11 TO 19 POUND CLASS  
ROUND COLLAR RETAINERS

(A)





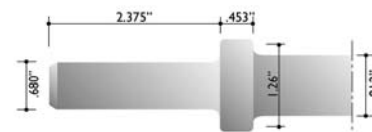
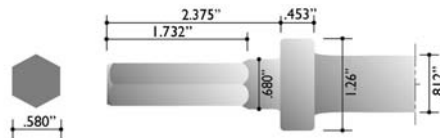

Class A Pricing



**ROUND RETAINER**

**.580 HEX SHANK**

**.680 ROUND SHANK**

	Overall Length	Part Number	Unit Price	Overall Length	Part Number	Unit Price
 Moil Point	9"	P5809RC	10.92	9"	P6809RC	10.92
	12"	P5812RC	13.01	12"	P6812RC	13.01
	18"	P5818RC	16.54	18"	P6818RC	16.54
	24"	P5824RC-36	21.50	24"	P6824RC-36	21.50
	36"	P5836RC-36	29.99	36"	P6836RC-36	29.99
	48"	P5848RC-36	38.04	48"	P6848RC-36	38.04
	60"	P5860RC-36	46.31	60"	P6860RC-36	46.31
	72"	P5872RC-36	54.80	72"	P6872RC-36	54.80
	84"	P5884RC-36	63.18	84"	P6884RC-36	63.18
96"	P5896RC-36	71.56	96"	P6896RC-36	71.56	
 Narrow Chisel	9"	C5809RC	10.92	9"	C6809RC	10.92
	12"	C5812RC	13.01	12"	C6812RC	13.01
	18"	C5818RC	16.54	18"	C6818RC	16.54
	24"	C5824RC-36	21.50	24"	C6824RC-36	21.50
	36"	C5836RC-36	29.99	36"	C6836RC-36	29.99
	48"	C5848RC-36	38.04	48"	C6848RC-36	38.04
	60"	C5860RC-36	46.31	60"	C6860RC-36	46.31
	72"	C5872RC-36	54.80	72"	C6872RC-36	54.80
	84"	C5884RC-36	63.18	84"	C6884RC-36	63.18
96"	C5896RC-36	71.56	96"	C6896RC-36	71.56	
 1.5" Wide Chisel	9"	C5809RC-15	13.01	9"	C6809RC-15	13.01
	12"	C5812RC-15	15.16	12"	C6812RC-15	15.16
	18"	C5818RC-15	19.02	18"	C6818RC-15	19.02
	24"	C5824RC-15-36	23.93	24"	C6824RC-15-36	23.93
	36"	C5836RC-15-36	32.41	36"	C6836RC-15-36	32.41
	48"	C5848RC-15-36	40.47	48"	C6848RC-15-36	40.47
	60"	C5860RC-15-36	48.85	60"	C6860RC-15-36	48.85
72"	C5872RC-15-36	57.23	72"	C6872RC-15-36	57.23	
 2" Wide Chisel	9"	C5809RC-20	14.77	9"	C6809RC-20	14.77
	12"	C5812RC-20	16.76	12"	C6812RC-20	16.76
	18"	C5818RC-20	20.40	18"	C6818RC-20	20.40
	24"	C5824RC-20-36	25.03	24"	C6824RC-20-36	25.03
	36"	C5836RC-20-36	33.52	36"	C6836RC-20-36	33.52
	48"	C5848RC-20-36	41.62	48"	C6848RC-20-36	41.62
	60"	C5860RC-20-36	49.95	60"	C6860RC-20-36	49.95
72"	C5872RC-20-36	58.38	72"	C6872RC-20-36	58.38	

\*For non-collar items, substitute NC for RC.

\*For 3/4" hex, substitute -34 for -36. Use NC for non-collar or RC for round collar.

\*For 7/8" hex, substitute -78 for -36. Use NC for non-collar or RC for round collar.

\*Round collar tools are available up to 240", please call.



Ⓐ
 TOOL BITS FOR  
**PNEUMATIC  
 CHIPPING HAMMERS**  
 11 TO 19 POUND CLASS  
**ROUND COLLAR RETAINERS**





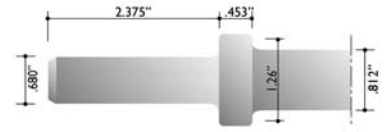
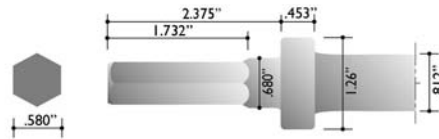





Class A Pricing



**ROUND RETAINER**

**.580 HEX SHANK**

**.680 ROUND SHANK**

	Overall Length	Part Number	Unit Price	Overall Length	Part Number	Unit Price
 <b>2.5" Wide Chisel</b>	9"	C5809RC-25	24.92	9"	C6809RC-25	24.92
	12"	C5812RC-25	28.50	12"	C6812RC-25	28.50
	18"	C5818RC-25	31.92	18"	C6818RC-25	31.92
	24"	C5824RC-25-36	35.72	24"	C6824RC-25-36	35.72
	36"	C5836RC-25-36	43.17	36"	C6836RC-25-36	43.17
	48"	C5848RC-25-36	48.68	48"	C6848RC-25-36	48.68
	60"	C5860RC-25-36	55.07	60"	C6860RC-25-36	55.07
	72"	C5872RC-25-36	63.18	72"	C6872RC-25-36	63.18
 <b>3" Wide Chisel</b>	9"	C5809RC-30	27.29	9"	C6809RC-30	27.29
	12"	C5812RC-30	30.87	12"	C6812RC-30	30.87
	18"	C5818RC-30	34.29	18"	C6818RC-30	34.29
	24"	C5824RC-30-36	37.82	24"	C6824RC-30-36	37.82
	36"	C5836RC-30-36	45.48	36"	C6836RC-30-36	45.48
	48"	C5848RC-30-36	51.05	48"	C6848RC-30-36	51.05
	60"	C5860RC-30-36	57.45	60"	C6860RC-30-36	57.45
 <b>4" Wide Chisel</b>	12"	C5812RC-40	44.66	12"	C6812RC-40	44.66
 <b>Clay Spade</b>	15"	CS-580RC	79.50	15"	CS-680RC	79.50
 <b>Sure Lock Floor Scraper</b>	11"	FS-2MML	126.79	11"	FS-2MML	126.79
 <b>Floor Scraper Shank</b>	16"	FSS-580RC	25.97	16"	FSS-680RC	25.97
 <b>I Piece Bush Tool</b>	9.5"	BHI-580RC	55.24	9.5"	BHI-680RC	55.24
 <b>Carbide Bush Tool</b>				9.5"	BHC-680RC (2"x2" 25 teeth)	210.00
 <b>Ground Rod Driver</b>	10"	GD58RC34	56.01	10"	GD68RC34	56.01



(A)

# TOOL BITS FOR PNEUMATIC CHIPPING HAMMERS

11 TO 19 POUND CLASS  
OVAL COLLAR RETAINERS

(A)





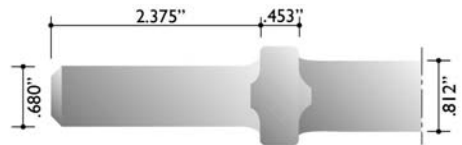
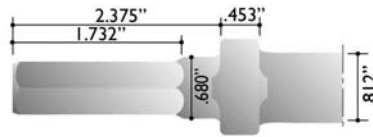

Class A Pricing



**OVAL RETAINER**

**.580 HEX SHANK**

**.680 ROUND SHANK**

	Overall Length	Part Number	Unit Price	Overall Length	Part Number	Unit Price
 <p><b>Moil Point</b></p>	9"	P5809OC	10.92	9"	P6809OC	10.92
	12"	P5812OC	13.01	12"	P6812OC	13.01
	18"	P5818OC	16.54	18"	P6818OC	16.54
	24"	P5824OC-36	21.50	24"	P6824OC-36	21.50
	36"	P5836OC-36	29.99	36"	P6836OC-36	29.99
	48"	P5848OC-36	38.04	48"	P6848OC-36	38.04
	60"	P5860OC-36	46.31	60"	P6860OC-36	46.31
	72"	P5872OC-36	54.80	72"	P6872OC-36	54.80
	84"	P5884OC-36	63.18	84"	P6884OC-36	63.18
96"	P5896OC-36	71.56	96"	P6896OC-36	71.56	
 <p><b>Narrow Chisel</b></p>	9"	C5809OC	10.92	9"	C6809OC	10.92
	12"	C5812OC	13.01	12"	C6812OC	13.01
	18"	C5818OC	16.54	18"	C6818OC	16.54
	24"	C5824OC-36	21.50	24"	C6824OC-36	21.50
	36"	C5836OC-36	29.99	36"	C6836OC-36	29.99
	48"	C5848OC-36	38.04	48"	C6848OC-36	38.04
	60"	C5860OC-36	46.31	60"	C6860OC-36	46.31
	72"	C5872OC-36	54.80	72"	C6872OC-36	54.80
	84"	C5884OC-36	63.18	84"	C6884OC-36	63.18
96"	C5896OC-36	71.56	96"	C6896OC-36	71.56	
 <p><b>1.5" Wide Chisel</b></p>	9"	C5809OC-15	13.01	9"	C6809OC-15	13.01
	12"	C5812OC-15	15.16	12"	C6812OC-15	15.16
	18"	C5818OC-15	19.02	18"	C6818OC-15	19.02
	24"	C5824OC-15-36	23.93	24"	C6824OC-15-36	23.93
	36"	C5836OC-15-36	32.41	36"	C6836OC-15-36	32.41
	48"	C5848OC-15-36	40.47	48"	C6848OC-15-36	40.47
	60"	C5860OC-15-36	48.85	60"	C6860OC-15-36	48.85
72"	C5872OC-15-36	57.23	72"	C6872OC-15-36	57.23	
 <p><b>2" Wide Chisel</b></p>	9"	C5809OC-20	14.77	9"	C6809OC-20	14.77
	12"	C5812OC-20	16.76	12"	C6812OC-20	16.76
	18"	C5818OC-20	20.40	18"	C6818OC-20	20.40
	24"	C5824OC-20-36	25.03	24"	C6824OC-20-36	25.03
	36"	C5836OC-20-36	33.52	36"	C6836OC-20-36	33.52
	48"	C5848OC-20-36	41.62	48"	C6848OC-20-36	41.62
	60"	C5860OC-20-36	49.95	60"	C6860OC-20-36	49.95
72"	C5872OC-20-36	58.38	72"	C6872OC-20-36	58.38	

\*Oval collar tools are available up to 240", please call.



(A)
 TOOL BITS FOR  
**PNEUMATIC CHIPPING HAMMERS**  
 11 TO 19 POUND CLASS  
**OVAL COLLAR RETAINERS**





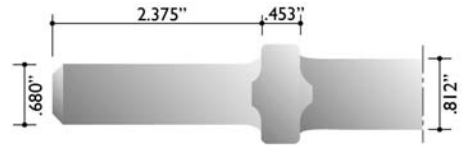
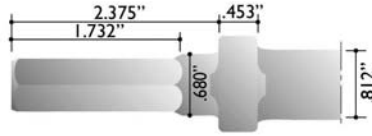





Class A Pricing



**OVAL RETAINER**

**.580 HEX SHANK**

**.680 ROUND SHANK**

	Overall Length	Part Number	Unit Price	Overall Length	Part Number	Unit Price
 <b>2.5" Wide Chisel</b>	9"	C5809OC-25	24.92	9"	C6809OC-25	24.92
	12"	C5812OC-25	28.50	12"	C6812OC-25	28.50
	18"	C5818OC-25	31.92	18"	C6818OC-25	31.92
	24"	C5824OC-25-36	35.72	24"	C6824OC-25-36	35.72
	36"	C5836OC-25-36	43.17	36"	C6836OC-25-36	43.17
	48"	C5848OC-25-36	48.68	48"	C6848OC-25-36	48.68
	60"	C5860OC-25-36	55.07	60"	C6860OC-25-36	55.07
	72"	C5872OC-25-36	63.18	72"	C6872OC-25-36	63.18
 <b>3" Wide Chisel</b>	9"	C5809OC-30	27.29	9"	C6809OC-30	27.29
	12"	C5812OC-30	30.87	12"	C6812OC-30	30.87
	18"	C5818OC-30	34.29	18"	C6818OC-30	34.29
	24"	C5824OC-30-36	37.82	24"	C6824OC-30-36	37.82
	36"	C5836OC-30-36	45.48	36"	C6836OC-30-36	45.48
	48"	C5848OC-30-36	51.05	48"	C6848OC-30-36	51.05
	60"	C5860OC-30-36	57.45	60"	C6860OC-30-36	57.45
 <b>4" Wide Chisel</b>	12"	C5812OC-40	44.66	12"	C6812OC-40	44.66
 <b>Clay Spade</b>	15"	CS-580OC	79.50	15"	CS-680OC	79.50
 <b>Sure Lock Floor Scraper</b>	11"	FS-2MML	126.79	11"	FS-2MML	126.79
 <b>Floor Scraper Shank</b>	16"	FSS-580OC	25.97	16"	FSS-680OC	25.97
 <b>I Piece Bush Tool</b>	9.5"	BHI-580OC	55.24	9.5"	BHI-680OC	55.24
 <b>Carbide Bush Tool</b>				9.5"	BHC-680OC (2"x2" 25 teeth)	210.00
 <b>Ground Rod Driver</b>	10"	GD58OC34	56.01	10"	GD68OC34	56.01



Ⓑ

TOOL BITS FOR  
PNEUMATIC

Ⓑ



**PAVEMENT BREAKERS**

20 TO 30  
POUND CLASS

*Speedsharp Breaker Steel*



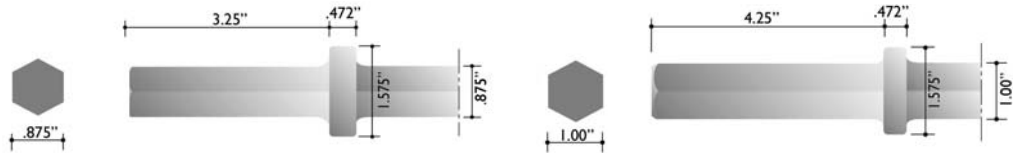

30 TO 40  
POUND CLASS

Class B Pricing



**7/8" X 3 1/4" SHANK**

**1 X 4 1/4" SHANK**

	U.C. Length	Part Number	Unit Price	U.C. Length	Part Number	Unit Price
 <p><b>Moil Point</b></p>	14"	PI0114	21.77	14"	PI0214	23.13
	18"	PI0118	23.81	18"	PI0218	26.20
	24"	PI0124	29.31	24"	PI0224	30.22
	36"	PI0136	36.74	36"	PI0236	42.36
	48"	PI0148	45.03	48"	PI0248	58.63
	60"	PI0160	55.34	60"	PI0260	73.83
	72"	PI0172	61.81	72"	PI0272	90.32
	84"	PI0184	75.98	84"	PI0284	107.28
96"	PI0196	88.85	96"	PI0296	124.29	
 <p><b>Narrow Chisel</b></p>	14"	CI0114	21.77	14"	CI0214	23.13
	18"	CI0118	23.81	18"	CI0218	26.20
	24"	CI0124	29.31	24"	CI0224	30.22
	36"	CI0136	36.74	36"	CI0236	42.36
	48"	CI0148	45.03	48"	CI0248	58.63
	60"	CI0160	55.34	60"	CI0260	73.83
	72"	CI0172	61.81	72"	CI0272	90.32
	84"	CI0184	75.98	84"	CI0284	107.28
96"	CI0196	88.85	96"	CI0296	124.29	
<p><b>3" Wide Chisel</b></p>	14"	CC1114	29.38	14"	CC11214	29.88
	18"	CC11118	31.92	18"	CC11218	34.59
	24"	CC11124	38.22	24"	CC11224	40.72
	36"	CC11136	57.89	36"	CC11236	64.92
	48"	CC11148	74.06	48"	CC11248	93.44
	60"	CC11160	91.00	60"	CC11260	121.85
	72"	CC11172	106.82	72"	CC11272	149.97
	84"	CC11184	118.96	84"	CC11284	177.93
96"	CC11196	133.48	96"	CC11296	206.28	
 <p><b>Asphalt Cutter</b></p>	11"	ACI01	74.90	11"	ACI02	74.90
 <p><b>Clay Spade</b></p>	16"	CSI01	96.62	16"	CSI02	97.80
 <p><b>I Piece Bush Tool</b></p>	12"	BHI01	97.24	10"	BHI02	87.89

\*Above tools available up to 240", please call.



ⓑ

TOOL BITS FOR  
PNEUMATIC

ⓑ



**PAVEMENT BREAKERS**

30 TO 90 POUND CLASS  
*Speedsharp Breaker Steel*



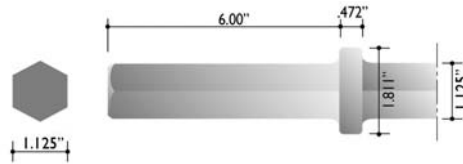

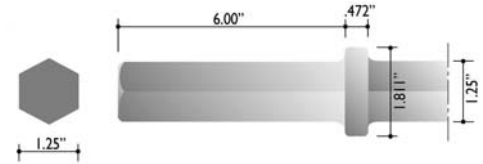

Class B Pricing



1 1/8" X 6" SHANK



1 1/4" X 6" SHANK

	U.C. Length	Part Number	Unit Price	U.C. Length	Part Number	Unit Price
 <p><b>Moil Point</b></p>	14"	PI0314	26.20	14"	PI0414	29.94
	18"	PI0318	29.31	18"	PI0418	32.94
	24"	PI0324	34.25	24"	PI0424	38.61
	36"	PI0336	50.35	36"	PI0436	62.37
	48"	PI0348	70.76	48"	PI0448	90.77
	60"	PI0360	92.25	60"	PI0460	118.56
	72"	PI0372	112.72	72"	PI0472	147.19
	84"	PI0384	133.25	84"	PI0484	175.82
96"	PI0396	153.77	96"	PI0496	202.08	
 <p><b>Narrow Chisel</b></p>	14"	CI0314	26.20	14"	CI0414	29.94
	18"	CI0318	29.31	18"	CI0418	32.94
	24"	CI0324	34.25	24"	CI0424	38.61
	36"	CI0336	50.35	36"	CI0436	62.37
	48"	CI0348	70.76	48"	CI0448	90.77
	60"	CI0360	92.25	60"	CI0460	118.56
	72"	CI0372	112.72	72"	CI0472	147.19
	84"	CI0384	133.25	84"	CI0484	175.82
96"	CI0396	153.77	96"	CI0496	202.08	
 <p><b>3" Wide Chisel</b></p>	14"	CC11314	33.34	14"	CC11414	36.63
	18"	CC11318	35.83	18"	CC11418	40.82
	24"	CC11324	44.34	24"	CC11424	49.11
	36"	CC11336	71.11	36"	CC11436	81.09
	48"	CC11348	102.69	48"	CC11448	105.01
	60"	CC11360	134.32	60"	CC11460	155.19
	72"	CC11372	165.79	72"	CC11472	192.83
	84"	CC11384	197.32	84"	CC11484	230.43
96"	CC11396	228.84	96"	CC11496	266.94	
 <p><b>Asphalt Cutter</b></p>	11"	AC103	78.07	11"	AC104	80.94
 <p><b>Clay Spade</b></p>	16"	CS103	102.69	16"	CS104	108.01
 <p><b>I Piece Bush Tool</b></p>	10"	BH103	87.89	10"	BH104	91.85



\*Above tools available up to 240", please call.

TOOL BITS FOR  
PNEUMATIC  
**PAVEMENT BREAKERS**

30 TO 90 POUND CLASS

*Speedsharp Breaker Steel*

Class B Pricing

	1" x 4 1/4"			1 1/8" x 6"			1 1/4" x 6"		
	Pin Size	Part Number	Unit Price	Pin Size	Part Number	Unit Price	Pin Size	Part Number	Unit Price
 Pin Driver	5/8"	PD10258	81.65	5/8"	PD10358	87.89	5/8"	PD10458	89.19
	3/4"	PD10234	81.65	3/4"	PD10334	87.89	3/4"	PD10434	89.19
	7/8"	PD10278	81.65	7/8"	PD10378	87.89	7/8"	PD10478	89.19
	1"	PD1021	81.65	1"	PD1031	87.89	1"	PD1041	89.19
	1 1/4"	PD102114	144.93	1 1/4"	PD103114	144.93	1 1/4"	PD104114	144.93
	1 1/2"	PD102112	154.50	1 1/2"	PD103112	154.50	1 1/2"	PD104112	154.50
	1 3/4"	PD102134*	167.84	1 3/4"	PD103134*	167.84	1 3/4"	PD104134*	167.84
	2"	PD1022*	180.59	2"	PD1032*	180.59	2"	PD1042*	180.59
 Ground Driver	5/8"	GD10258	73.66	5/8"	GD10358	77.79	5/8"	GD10458	83.74
	3/4"	GD10234	73.66	3/4"	GD10334	77.79	3/4"	GD10434	83.74
	7/8"	GD10278	83.13	7/8"	GD10378	87.15	7/8"	GD10478	93.21
	1"	GD1021	91.12	1"	GD1031	95.99	1"	GD1041	106.09
 Pipe Driver with Cup	Up to 1.5" pipe (2" ID cup)				PDR103-112	223.17	PDR104-112		
	Up to 2" pipe (2.5" ID cup)				PDR103-2	223.17	PDR104-2		

\*Pin drivers with a pin size of 1 3/4" and 2" are two piece systems with a driver and a cup.

**TENT STAKE DRIVER SHANKS & CUPS**

Class B Pricing

7/8" x 4 1/4"		1 1/8" x 6"		1 1/4" x 6"	
Part Number	Unit Price	Part Number	Unit Price	Part Number	Unit Price
TSDS111	80.85	TSDS103B	96.60	TSDS104	101.30



Part Number	Cup Size	Unit Price
TSCUP-114	1-1/4"	117.76
TSCUP-112	1-1/2"	150.81
TSCUP-134	1-3/4"	159.65
TSCUP-2	2"	159.65
TSCUP-212	2-1/2"	202.65
TSCUP-3	3"	257.17





Ⓐ

# TOOL BITS FOR PNEUMATIC JUMBO RIVET BUSTERS

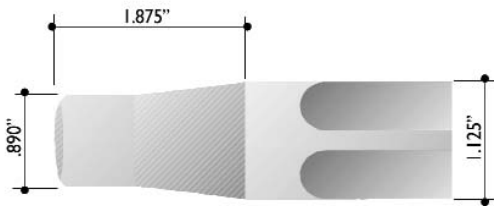
Class A Pricing

Ⓐ



	Overall Length	Part Number	Unit Price
<b>Moil Point</b> 	10"	JRBP10-86	17.54
	12"	JRBP12-86	21.06
	18"	JRBP18-86	29.66
	24"	JRBP24-92	32.85
	36"	JRBP36-92	37.54
	48"	JRBP48-92	47.19
	60"	JRBP60-92	55.46
	72"	JRBP72-92	64.88
<b>Narrow Chisel</b> 	10"	JRBC10-86	17.54
	12"	JRBC12-86	21.06
	18"	JRBC18-86	29.66
	24"	JRBC24-92	32.85
	36"	JRBC36-92	37.54
	48"	JRBC48-92	47.19
	60"	JRBC60-92	55.46
	72"	JRBC72-92	64.88
<b>2" Wide Chisel</b> 	12"	JRBC12-20-86	31.45
<b>Ripper</b> 	9"	JRBR9-86	26.58

Jumbo Rivet Buster tools are available in lengths up to 144".

## TAMPERS

Class B Pricing

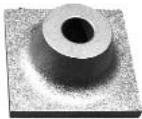
Ⓑ

6" X 6" PAD

Part Number	Unit Price
TP6	146.38



1" X 4 1/4"

Part Number	Unit Price
TPS102	59.83



1 1/8" X 6"

Part Number	Unit Price
TPS103	59.83



1 1/4" X 6"

Part Number	Unit Price
TPS104	59.83

Ⓑ

# SURE LOCK FLOOR SCRAPER SYSTEM



## SURE LOCK

Special Spring Steel Inserts **keep nuts tight** until you need to change the blades. The nuts may be used over and over again.

## TOUGH BLADE

Stainless Steel - **resists cracking** unlike the high carbon spring steel used on other systems.

## UNIVERSAL SHANKS

Shanks available to fit **every electric demo and roto hammer** - plus oval and round collar pneumatic chipping hammers!

## SHANK STYLES

- 3/4" Demo Steel
- Spline Drive Steel
- SDS Max
- SDS Plus
- Kango 21MM Style
- Makita 8900 Style
- Wacker 3/4" x 3-1/4" Style
- 1-1/8" Hex/Notch
- Hilti 805/905 Style
- .590" Hex Edco Style
- 7/8" Hex Edco Style
- Chipping hammer - round or oval collar

**A**











SURE LOCK

**A**

# FLOOR SCRAPERS



Class A Pricing

**FLOOR SCRAPER SHANKS FOR ELECTRIC HAMMERS**



	Part Number	Shank Style	Unit Price
	FSS-DEMO	3/4" Hex Demo	25.97
	FSS-ROTARY	Spline Drive	25.97
	FSS-MAX	SDS Max	37.76
	FSS-KGO	Kango 21MM Style	27.62
	FSS-PLUS	SDS Plus	25.97
	FSS-MKTA	Makita 8900N Style	45.81
	FSS-WKR	Wacker 3/4" x 3-1/4" Style	28.83
	FSS-103-B	1-1/8" Hex/Notch	45.81
	FSS-905-78	7/8" Hex Demo	55.13
	FSS-E59*	.590" Hex Edco Style	31.45
	FSS-E78*	7/8" Hex Edco Style	32.93

\*POGO STICK PNEUMATIC SCRAPERS.

**TURNING FLOOR SCRAPER SHANKS FOR ELECTRIC HAMMERS**

	Part Number	Shank Style	Unit Price
	FSST-DEMO	3/4" Hex Demo	33.02
	FSST-ROTARY	Spline Drive	33.02
	FSST-KGO	Kango 21MM Style	34.45

**FLOOR SCRAPER SHANKS FOR PNEUMATIC HAMMERS**

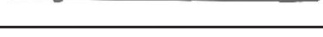
	Part Number	Shank Style	Unit Price
	FSS-580RC	.580 Hex Shank Round Collar	25.97
	FSS-680RC	.680 Round Shank Round Collar	25.97
	FSS-580OC	.580 Hex Shank Oval Collar	25.97
	FSS-680OC	.680 Round Shank Oval Collar	25.97

**HEAD ASSEMBLY**

Part Number	Unit Price
FS-2MML	126.79
Sure Lock Floor Scraper with 2mm blade	

**ACCESSORIES**

Part Number	Unit Price
FSB-1-2MM	12.59
1.2mm blade	
FSB-1-5MM	15.11
1.5mm blade	
FSB-2MM	19.50
2mm blade(standard)	



Part Number	Unit Price
FSRKIT-L	27.56
Repair Kit	

**LONG REACH SCALER**

Part Number	Unit Price
LRSC9-40	42.72
4" wide scaler chisel	

# SPECIALTY SCRAPERS



## *Jumbo 4.5" Wide Chisel*

### SHANK STYLES

- 3/4" Hex Demo
- Spline Drive
- SDS Max
- Hilti 805/905 Style



## *3" Bent Chisel*

### SHANK STYLES

- 3/4" Hex Demo
- Spline Drive
- SDS Max
- Kango 21MM Style
- SDS Plus
- Zip Gun
- Weld Flux Scalers









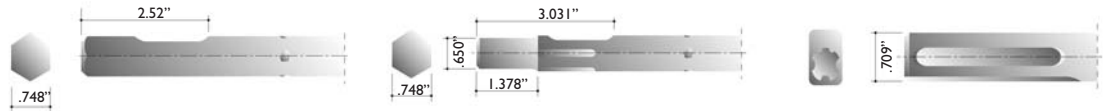



**(A)**

# TOOL BITS FOR ELECTRIC CHIPPING HAMMERS

**(A)**

Class A Pricing

**3/4" HEX DEMO****SPLINE DRIVE****SDS MAX**

	Overall Length	Chisel Width	Part Number	Unit Price	Overall Length	Chisel Width	Part Number	Unit Price	Overall Length	Chisel Width	Part Number	Unit Price
 <b>Moil Point</b>	12"		DP12	9.70	12"		RP12	11.47	12"		MP12	14.16
	20"		DP20	13.01	18"		RP18	14.28	16"		MP16	20.12
									24"		MP24	36.82
 <b>Narrow Chisel</b>	12"		DC12	9.70	12"		RC12	11.47	12"		MC12	14.16
	20"		DC20	13.01	18"		RC18	14.28	16"		MC16	20.12
									24"		MC24	36.82
 <b>Wide Chisel</b>	12"	1.5"	DC12-15	14.89	12"	1.5"	RC12-15	18.30	12"	1.5"	MC12-15	18.30
	20"	1.5"	DC20-15	18.25	18"	1.5"	RC18-15	21.12	16"	1.5"	MC16-15	22.49
	12"	2"	DC12-20	18.86	12"	2"	RC12-20	23.81	12"	2"	MC12-20	25.03
	20"	2"	DC20-20	22.22	18"	2"	RC18-20	26.68	16"	2"	MC16-20	31.92
	12"	2.5"	DC12-25	20.07	12"	2.5"	RC12-25	25.08	12"	2.5"	MC12-25	26.07
	20"	2.5"	DC20-25	23.43	18"	2.5"	RC18-25	27.84	16"	2.5"	MC16-25	33.08
	12"	3"	DC12-30	21.17	12"	3"	RC12-30	26.63	12"	3"	MC12-30	27.95
20"	3"	DC20-30	24.59	18"	3"	RC18-30	29.38	16"	3"	MC16-30	34.29	
 <b>Jumbo Chisel</b>	12"	4.5"	DC12-45	44.66	12"	4.5"	RC12-45	44.66	12"	4.5"	MC12-45	47.02
	18"	4.5"	DC18-45	52.15	18"	4.5"	RC18-45	52.15				
 <b>Bent Chisel</b>	11.75"	3"	DCB12-30	31.53	12"	3"	RCB12-30	31.53	12"	3"	MCB12-30	33.85
 <b>Asphalt Cutter</b>	19.5"	4.875"	AC-DEMO	92.56	19.5"	4.875"	AC-ROTARY	106.18	19.5"	4.875"	AC-MAX	101.43
 <b>Clay Spade</b>	19.5"	4.375"	CS-DEMO	79.50	19.5"	4.375"	CS-ROTARY	94.15	19.5"	4.375"	CS-MAX	81.26
 <b>Sure Lock Floor Scraper</b>	11"	6"	FS-2MML	126.79	11"	6"	FS-2MML	126.79	11"	6"	FS-2MML	126.79
 <b>Floor Scraper Shank</b>	16"		FSS-DEMO	25.97	16"		FSS-ROTARY	25.97	16"		FSS-MAX	37.76
 <b>Floor Scraper Shank - Turning</b>	15.75"		FSST-DEMO	33.02	15.75"		FSST-ROTARY	33.02				
 <b>I Piece Bush Tool</b>	9.5"		BHI-DEMO	56.89	9.5"		BHI-ROTARY	59.15	9.5"		BHI-MAX	58.93
 <b>Carbide Bush Tool</b>	9.5"		BHC-DEMO (2"x2" 25 teeth)	210.00	9.5"		BHC-ROTARY (2"x2" 25 teeth)	210.00	9.5"		BHC-MAX (2"x2" 25 teeth)	210.00
 <b>Ground Rod Driver</b>	10"		GD34-DEMO	55.24	10"		GD34-ROTARY	55.24	10"		GD34-MAX	58.77

(A)



# TOOL BITS FOR ELECTRIC CHIPPING HAMMERS

(A)





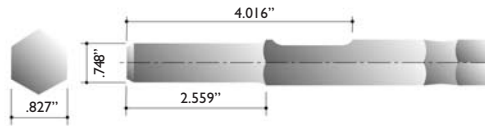







Class A Pricing



FITS KANGO 21MM

SDS PLUS

	Overall Length	Chisel Width	Part Number	Unit Price	Overall Length	Chisel Width	Part Number	Unit Price
<b>Moil Point</b> 	12"		KPI2	16.98	10"		PPI0	9.92
	15"		KPI5	20.56				
	18"		KPI8	23.59				
<b>Narrow Chisel</b> 	12"		KC12	16.98	10"		PC10	9.92
	15"		KC15	20.56				
	18"		KC18	23.59				
<b>Wide Chisel</b> 	12"	2"	KC12-20	25.97	10"	1.5"	PC10-15	16.54
	15"	2"	KC15-20	30.32	10"	2"	PC10-20	17.54
	18"	2"	KC18-20	32.19	7"	3"	PC07-30	23.15
	12"	3"	KC12-30	31.36				
	15"	3"	KC15-30	36.82				
18"	3"	KC18-30	40.58					
<b>Bent Chisel</b> 	12"	2"	KCB12-20	26.90	7"	3"	PCB07-30	23.59
	12"	3"	KCB12-30	31.65				
<b>Asphalt Cutter</b> 	19.5"	4.875"	AC-KGO	110.91				
<b>Clay Spade</b> 	19.5"	4.375"	CS-KGO	110.91				
<b>Sure Lock Floor Scraper</b> 	11"	6"	FS-2MML	126.79	11"	6"	FS-2MML	126.79
<b>Floor Scraper Shank</b> 	16"		FSS-KGO	27.62	16"		FSS-PLUS	25.97
<b>Floor Scraper Shank - Turning</b> 	15.75"		FSST-KGO	34.45				
<b>1 Piece Bush Tool</b> 	9.5"		BHI-KGO	77.89				
<b>Ground Rod Driver</b> 	12"		GD34-KGO	58.77				







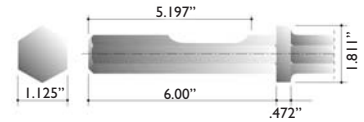
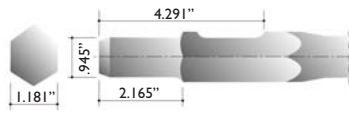

**(A)**

# TOOL BITS FOR ELECTRIC CHIPPING HAMMERS

**(A)**

Class A Pricing

**FITS MAKITA 8900N****FITS WACKER 3/4\" x 3-1/4\"****1-1/8\" HEX/NOTCH\***

	Overall Length	Chisel Width	Part Number	Unit Price	Overall Length	Chisel Width	Part Number	Unit Price	U.C. Length	Chisel Width	Part Number	Unit Price
 <b>Moil Point</b>	15"		HP15	39.64	12"		WP12	16.54	14"		PI0314-B	28.89
	17"		HP17	41.95					18"		PI0318-B	33.02
 <b>Narrow Chisel</b>	15"		HC15	39.64	12"		WC12	16.54	14"		C10314-B	28.89
	17"		HC17	41.95					18"		C10318-B	33.02
 <b>Wide Chisel</b>	16"	3"	HC16-30	51.43	12"	3"	WC12-30	30.21	14"	3"	CCI1314-B	36.50
									18"	3"	CCI1318-B	38.92
 <b>Asphalt Cutter</b>									11"	4.875"	AC103-B	83.30
 <b>Clay Spade</b>	19.5"	4.375"	CS-MKTA	110.91					16"	4.375"	CS103-B	106.50
 <b>Sure Lock Floor Scraper</b>	11"	6"	FS-2MML	126.79	11"	6"	FS-2MML	126.79	11"	6"	FS-2MML	126.79
 <b>Floor Scraper Shank</b>	16"		FSS-MKTA	45.81	16"		FSS-WKR	28.83	16"		FSS-103-B	45.81
 <b>I Piece Bush Tool</b>	9.5"		BHI-MKTA	55.24					10"		BH103-B	95.92

\* All electric paving breakers offer the option of using regular (without the notch) 1-1/8" hex bits. These cost less and offer a wide range of bit styles (see pages 9 & 10). Simply use the latch fitted at the bottom of the front head of your hammer to hold the bit in by its collar, just as in pneumatic paving breakers.

(A)



# TOOL BITS FOR ELECTRIC CHIPPING HAMMERS

(A)











Class A Pricing

## 7/8" HEX DEMO

*Fits Hilti 805/905*

## 12MM DEMO

*Fits Makita HK1810*

	Overall Length	Chisel Width	Part Number	Unit Price	Overall Length	Chisel Width	Part Number	Unit Price
	14"		NP14-78	29.77	9"		MKP9	7.28
	19"		NP19-78	33.08				
	27"		NP27-78	49.61				
	14"		NCI4-78	29.77	9"		MKC9	7.28
	19"		NCI9-78	33.08				
	27"		NC27-78	49.61				
	14"	2"	NCI4-20-78	40.79	6"	1.2"	MKC6-12	14.55
	19"	2"	NCI9-20-78	44.10	6"	2"	MKC6-20	16.98
	14"	3"	NCI4-30-78	44.10	9"	2"	MKC9-20	21.17
	19"	3"	NCI9-30-78	47.41				
	14"	4.5"	NCI4-45	61.74				
	19"	4.5"	NCI9-45	66.15				
	11"	6"	FS-2MML	126.79				
	16"		FSS-905-78	55.13				
			BHI-905	73.50				
			BHC-905 (2"x2" 25 teeth)	346.50				

# ELECTRIC CHIPPER STEEL HAMMER REFERENCE

Hammer Manufacturer	Shank Style	Corresponding Hammer Models
Atlas Copco	SDS MAX	PH5S, PHE-5S, PH-5S, PH6 6S, PHE 75, PHE 50S, PHE 40S, PHE 45S
	SPLINE	PH5H, PH11H, PB10H, PHE5H
	KANGO 21MM	PB6C, PB10, PB10C, PB14C, PH11C
	1-1/8" HEX/NOTCH	PB32B
Black & Decker	SDS PLUS	5009, 5013, 5014, 5016, 5053, 5054, 5056, 5057
	SDS MAX	5097, 5099
	SPLINE	5041, 5042, 5043, 5044, 5045, 5059, 5093, 5095, 5096, 5098
	1-1/8" HEX/NOTCH	5027

# ELECTRIC CHIPPER STEEL HAMMER REFERENCE

Hammer Manufacturer	Shank Style	Corresponding Hammer Models
Bosch	SDS PLUS	11207, 11210, 11211, 11212, 11213, 11215, 11221, 11222, 11224, 11228, 11236
	SDS MAX	11214EVS, 11216, 11223, 11227, 11230, 11231, 11235, 11245, 11309, 11311, 11312, 11313, 11316, 11318 EVS, 11388, GBH5, GBH5CE, GBH5/40DCE, GBH8DCE, GBH10/DC, GBH38, GSH4, GSH10C, GBH8165DCE, GBH7DCE, GBH5DCE, GBH5/40DE, GBH7/45DE, GBH11DE, GSH5CE, GSH11E
	3/4" HEX DEMO	11302, 11305, 11317 EVS, 12312, USH10
	SPLINE	11202, 11203, 11204, 11205, 11206, 11207, 11208, 11209, 11212, 11214, 11219, 11220, 11232, 11233, 11244E, 11306, 11307, 11310, 11314, 11387, GBH7.45D, GBH7.75DE, UBH6.35, UBH6.35D, UBH10.5, UBH12.5, USH6
	1-1/8" HEX/NOTCH	11304, 11308, 12308, 12314, HSH10, HSH27, HSH28, USH27
DeWalt	SDS PLUS	514K, 523K, 557K, 566K, 567K, D25101K, D25201K, D25203K, D25303K, D25304K, DW562K, DW565K, DW567K, DW570K
	SDS MAX	541K, 545K, D25500K, D25600K, DW540K, DW545K, DW541K, D25899K, D25901K
	3/4" HEX DEMO	5021K, DW558K, D25941K
	SPLINE	530K, 531K, 532K, 533K, 551K, D25550K, D25551K, D25650K, DW533K
Hilti	SDS PLUS	TE15C, TE24, TE25, TE104
	SDS MAX	TE54/52, TE-F52, 60, TE-F72, 92, TE-Y74, 75, TE76, TE-Y504, 505, TE-Y704, 705, TE42, TE55, TE60, TE70, TE72, TE74, TE75, TE92, TE504, TE704, TE104 WIDTH UNIT 55, WIDTH UNIT 75, WIDTH UNIT 76, WIDTH UNIT 76ATC
	7/8" HEX DEMO	TE805, TE905
Hitachi	SDS PLUS	DH22VB, DH22VD, DH24PC, DH24PB, DH30PC, VRI16, VRT22
	SDS MAX	DH40MA, DH40MB, DH40MR, H45MA, H60MA, H60MB, DH40MT, DH50MT
	3/4" HEX DEMO	H55SC
	SPLINE	DH38YE, DH38YF, DH40FA, DH40FB, DH40FR, DH50MB, DH50SB, DH505BK, DS50SB, H45FRV, H45SB
	KANGO 21MM	DH50SA, DH50SA1, H555C, H55SA
	MAKITA 8900N	H65SA, PH65A, H65SB
	1-1/8" HEX/NOTCH	H65, H85, H90SB
Kango	SDS PLUS	200, 285, 327, 422, 426, 430D
	SDS MAX	710MV, 760MV, 810MV, 850FV, 900HV, 1400MV, 760MVS, 850MVS, 810MVS, 845MVS
	3/4" HEX DEMO	638S, 900B, 900KS, 900S, 900XS, 1400B
	SPLINE	430S, 501S, 637S, 750S, 950KS, 950S, 950XS, 978S
	KANGO 21MM	900, 900X, 928, 950, 950K, 950X, 1400
	1-1/8" HEX/NOTCH	2500
Makita	SDS PLUS	HR160, HR1821, HR2000, HR2010, HR2400, HR2410, HR2420, HR2431, HR2445F, HR2455X, HR2511, HR3000C
	SDS MAX	HR500C, HM1100C, HM1100S, HM1200C, HM1202C, HR4000C, HR4500C, HR5001C
	3/4" HEX DEMO	HM1200B, HM1211B
	SPLINE	HM0810B, HM1140C, HM1242C, HR3520B, HR3520EB, HR3850B, HR3851, HR4040C, HR5000
	MAKITA 8900N	8900N, 8900-S, HK1300, HM0810T, HM1303, HM1400, HM1500
	1-1/8" HEX/NOTCH	HM1303B, HM1304BX, HM1500B, HM1800, HM1810
	12MM DEMO	HK1800, HK1800L, HK1810
Metabo	SDS PLUS	6010, 6018, 6020, 6024, 6026
	SDS MAX	6045, Bh6045S, BhE6045S
	SPLINE	11285, 11295, 11305, 11315, BhE6030S, RH66, RH99, RH99X, 1129, 1130, 6030, 6040, 6046
	WACKER 3/4"x3-1/4"	MH10S, MHE10S
Milwaukee	SDS PLUS	5302, 5303, 5312, 5317, 5320, 5324, 5343, 5344, 5347, 5348, 5359-21, 5360-21, 5362, 5362-6, 5366, 5366-21, 5368, 5368-21, 5368-22, 5369, 5382-21
	SDS MAX	5308, 5313, 531351
	3/4" HEX DEMO	5335
	SPLINE	5309, 5316, 5334, 5341, 5343, 5344, 5347, 5348, 5352, 5353
	1-1/8" HEX/NOTCH	5338
Ryobi	SDS PLUS	ED160, ED211
	SDS MAX	ER382K, DE382NP
	SPLINE	ED350K, ED382, ED382P, ER382
Wacker	SDS MAX	EHB-7SM, EHB7/230, EH9BLM, EHB11BLM
	SPLINE	EBH7S
	WACKER 3/4"x3-1/4"	EH8/220, EHL8Y/42, EHU8Y/220, EHUB10Y/220, LHB5, SH60K
	1-1/8" HEX/NOTCH	BH25, EH23, EH27





**(A)**

# TOOL BITS FOR PNEUMATIC ZIP GUNS

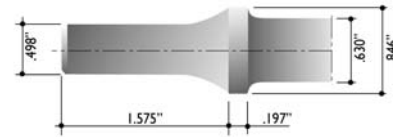
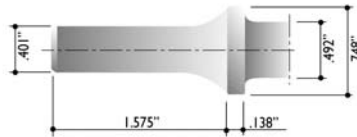

**(A)**

Class A Pricing

**BEE HIVE RETAINER****.401 TURN TYPE****.498 TURN TYPE**

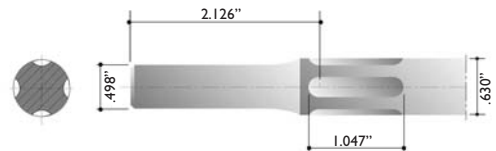
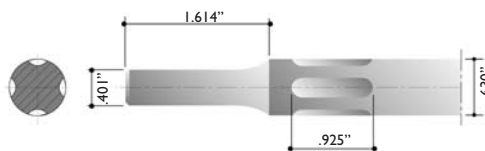
	Overall Length	Chisel Width	Part Number	Unit Price	Overall Length	Chisel Width	Part Number	Unit Price
 <b>Moil Point</b>	7"		ZGPTT40107	10.38				
	10"		ZGPTT40110	13.09				
	14"		ZGPTT40114	17.52				
 <b>Blank</b>	7"		ZGBTT40107	8.97				
	12"		ZGBTT40112	12.46				
	18"		ZGBTT40118	16.68				
	24"		ZGBTT40124	24.11				
	36"		ZGBTT40136	34.74				
 <b>Narrow Chisel</b>	7"	.50"	ZGCTT40107-50	10.38	7"	.64"	ZGCTT49807	13.91
	10"	.50"	ZGCTT40110-50	12.34	12"	.64"	ZGCTT49812	18.29
	12"	.50"	ZGCTT40112-50	14.27	18"	.64"	ZGCTT49818	25.13
	18"	.50"	ZGCTT40118-50	22.35				
	7"	.75"	ZGCTT40107	10.38				
	10"	.75"	ZGCTT40110	12.34				
	12"	.75"	ZGCTT40112	14.27				
	18"	.75"	ZGCTT40118	22.35				
 <b>2" Wide Chisel</b>	7"	2"	ZGCTT40107-20	19.46				
 <b>Taper Punch</b>	5.3"	.12"	ZGPTT40105	10.38	7"	.12"	ZGPTT49807	13.91
	7"	.1"	ZGPTT40107	11.34				

**QC RETAINER****.401 NON-TURN TYPE****.498 NON-TURN TYPE**

	Overall Length	Chisel Width	Part Number	Unit Price	Overall Length	Chisel Width	Part Number	Unit Price
 <b>Narrow Chisel</b>	7"	.75"	ZGCNT40107	12.26	7"	.75"	ZGCNT49807	13.22
	10"	.75"	ZGCNT40110	15.82	12"	.75"	ZGCNT49812	18.22
	12"	.75"	ZGCNT40112	19.58	18"	.75"	ZGCNT49818	24.90
	18"	.75"	ZGCNT40118	24.72				
 <b>Bent Chisel</b>	7"	1.25"	ZGBCNT40107-125	12.61	7"	1.25"	ZGBCNT49807-125	14.63
	10"	1.25"	ZGBCNT40110-125	16.66	12"	1.25"	ZGBCNT49812-125	20.46
	18"	1.25"	ZGBCNT40118-125	24.83				

WEST 800-858-8831

WWW.CHAMPIONCHISEL.COM

EAST 800-239-1434

(A)



# TOOL BITS FOR PNEUMATIC WELD FLUX SCALING HAMMERS

(A)





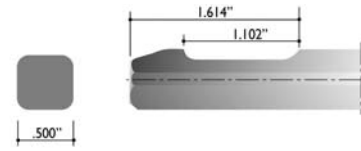
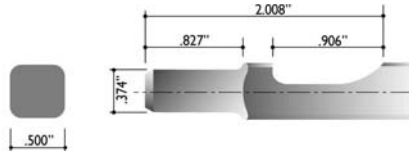

Class A Pricing



**CLECO STYLE**

**INGERSOLL RAND STYLE**

	Overall Length	Chisel Width	Part Number	Unit Price	Overall Length	Chisel Width	Part Number	Unit Price
 Moil Point	7"		SP20007	7.68	7"		SP10007	7.68
	9"		SP20009	8.57	12"		SP10012	9.57
	12"		SP20012	9.57	18"		SP10018	12.65
	18"		SP20018	12.65				
 Blank	7"		SB20007	6.48	7"		SB10007	6.48
	12"		SB20012	8.79	12"		SB10012	8.79
	18"		SB20018	11.43	18"		SB10018	11.43
 Narrow Chisel	7"		SC20007	7.68	7"		SC10007	7.68
	9"		SC20009	8.57	12"		SC10012	9.57
	12"		SC20012	9.57	18"		SC10018	12.65
	18"		SC20018	12.65	24"		SC10024	16.34
	24"		SC20024	16.34	30"		SC10030	23.43
	48"		SC20048	58.11				
 Wide Chisel	7"	1.375"	SC20007-14	8.32	7"	1.375"	SC10007-14	8.32
	12"	1.375"	SC20012-14	11.05	12"	1.375"	SC10012-14	11.05
	18"	1.375"	SC20018-14	13.19	18"	1.375"	SC10018-14	13.19
	7"	2"	SC20007-20	18.94	7"	2"	SC10007-20	18.94
	18"	2"	SC20018-20	27.76	12"	2"	SC10012-20	21.68
	24"	2"	SC20024-20	31.33	7"	3"	SC10007-30	23.43
	7"	3"	SC20007-30	23.43				
 Bent Chisel	7"	1.375"	SBC20007-14	8.45	7"	.75"	SBC10007	7.99
	12"	1.375"	SBC20012-14	11.21	12"	.75"	SBC10012	9.88
	18"	1.375"	SBC20018-14	14.11	7"	1.375"	SBC10007-14	8.45
	7"	2"	SBC20007-20	18.94	12"	1.375"	SBC10012-14	11.21
	7"	3"	SBC20007-30	23.43	18"	1.375"	SBC10018-14	14.11
					24"	1.375"	SBC10024-14	21.53
					30"	1.375"	SBC10030-14	27.83
					7"	2"	SBC10007-20	18.94
					7"	3"	SBC10007-30	23.43

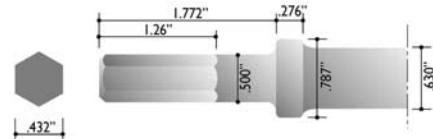
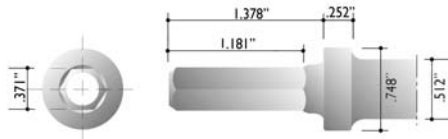

**.371 STYLE**

**.432 STYLE**

	Overall Length	Chisel Width	Part Number	Unit Price	Overall Length	Chisel Width	Part Number	Unit Price
 Narrow Chisel	6"	.75"	SC37106	8.86	8"	.75"	SC43208	17.14
	8"	.75"	SC37108	10.73	12"	.75"	SC43212	23.05
	10"	.75"	SC37110	11.87	18"	.75"	SC43218	27.31
	12"	.75"	SC37112	14.45				
	18"	.75"	SC37118	18.13				
	24"	.75"	SC37124	21.65				

WEST 800-858-8831

WWW.CHAMPIONCHISEL.COM

EAST 800-239-1434

# HOW TO ORDER BOOM MOUNTED DEMOLITION BITS

At last count there were over 500 separate hammers in existence, each with its own bit! You want to make sure the bit you order will fit the hammer you are ordering it for. All we need are a few facts to make this procedure painless and accurate:

## BRAND

Such as- Allied/Krupp, Bobcat, Caterpillar, Chicago Pneumatic/Atlas Copco, Gehl, Huskie/Jacty, Indeco, JCB, Kent, Kubota, Lifton, NPK, Okada, Rammer, Rock Ram, Stanley, Teledyne-Roxon/Toku, and Tramac/Montebert. These are some of the more popular brands, but it seems more are being added by the month! Call us for help!

## MODEL NUMBER

There are many schools of thought, but most manufacturers use a simple numbering system, such as the Allied 730, and Bobcat 2500. Some add letters, such as Indeco-MES 621. Sometimes the same brand has numbers that are very close, such as Kent 3G and Kent KF3, which sound alike, but are very different hammers. So make sure you have the entire model number.

## LENGTH

Industry practice is to specify overall length. Bits come in standard lengths associated with the brand and model number. Special lengths are available at special prices with extended lead times.

## POINT

The most popular are Moil Points: cone (like a pencil) or four sided (like a nail); and Chisels (like a standard screwdriver). Also available in Blunt Points.

## PRICING

Please call for pricing on all boom mounted demolition bits - including models not listed.

The drawings on the opposite page indicate some of the designs and point styles used in this industry. We refer to these in our catalog next to our part numbers to provide another check point in the process of selecting the right bit for your hammer.

Additional shank and chisel styles are available upon request. To inquire, please have available the following information: Manufacturer & Model Number of the hydraulic breaker  
Type of point or chisel style needed

All Demo bit chisels are Cross Cut unless specified as In-line.

# BOOM MOUNTED DEMOLITION BITS

## AVAILABLE CHISEL TYPES

Additional chisel types are available - please call.

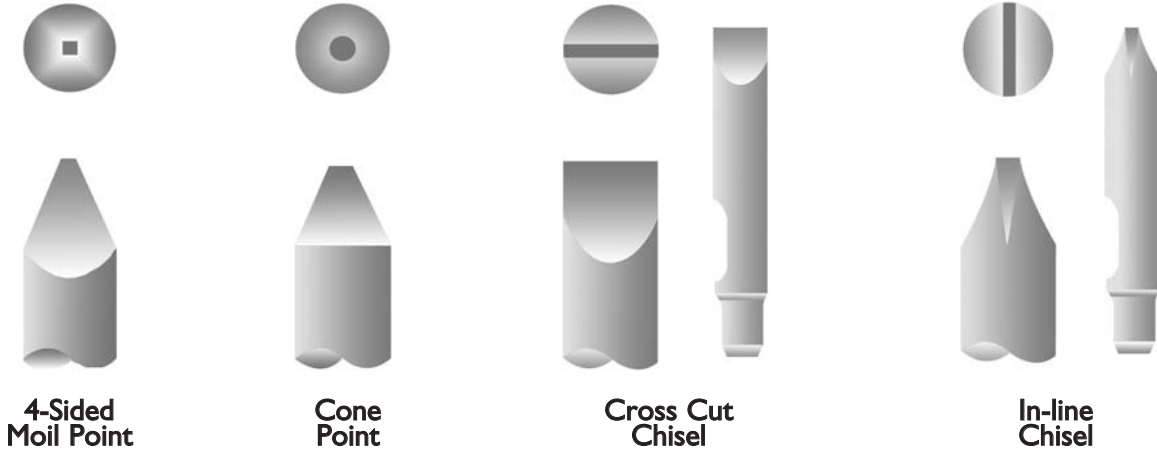

## AVAILABLE SHANK STYLES

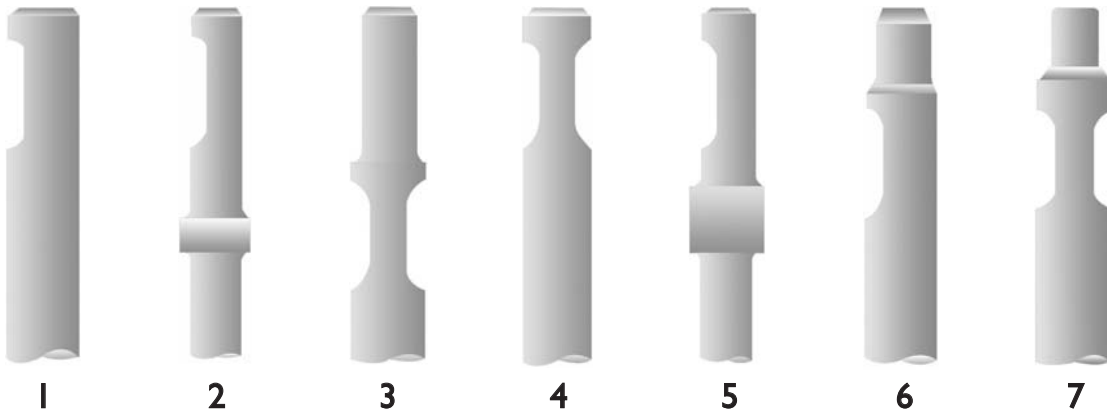

## DEMO/RAM NOMENCLATURE

ARI010-23CP

**ARI010** -  
Parent Number

**23**  
Designates Length of Tool  
Measured in inches OAL  
(fractions/decimals not included)

**CP**  
Type of Tip  
CP = Cone Point  
MP = Moil Point  
CH = Chisel  
BL = Blunt Tool

(Add '-IL' after  
'CH' if In-Line  
chisel is required)

All Demo bit chisels are Cross Cut unless specified as In-Line.

# BOOM MOUNTED DEMOLITION BITS

## BITS TO FIT ALLIED HAMMERS

Model Number	Overall Length	Approximate Body Diameter	Weight (lbs.)	Shank Style	Cone Point Part Number	Chisel Part Number
77	32"	3.25"	70	2	ARI100-32CP	ARI100-32CH
77	37"	3.25"	90	2	ARI100-37CP	ARI100-37CH
88	33"	4.00"	105	5	ARI200-33CP	ARI200-33CH
88	39"	4.00"	128	5	ARI200-39CP	ARI200-39CH
720	24"	2.75"	34	2	ARI020-24CP	ARI020-24CH
730	34"	3.25"	60	6	ARI030-34CP	ARI030-34CH
730	40"	3.25"	70	6	ARI030-40CP	ARI030-40CH
740	39"	4.00"	100	6	ARI035-39CP	ARI035-39CH
740	43"	4.00"	120	6	ARI035-43CP	ARI035-43CH
750B	39"	4.50"	175	4	ARI040B-39CP	ARI040B-39CH
750B	45"	4.50"	201	4	ARI040B-45CP	ARI040B-45CH

We make bits for all Allied Hammers - call for pricing.

## BITS TO FIT MELROE/BOBCAT HAMMERS

Model Number	Overall Length	Approximate Body Diameter	Weight (lbs.)	Shank Style	Cone Point Part Number	Chisel Part Number
2500/3500 Series	22"	2.50"	27	1	AR2500-22CP	AR2500-22CH
5500 Series	28"	2.75"	45	1	AR2550-28CP	AR2550-28CH
B-700	21"	2.00"	23	1	ARI660-21CP	ARI660-21CH
B-850	24"	2.50"	26	4	ARI610-24CP	ARI610-24CH

We make bits for all Melroe/Bobcat Hammers - call for pricing.

## BITS TO FIT HUSKIE HAMMERS

Model Number	Overall Length	Approximate Body Diameter	Weight (lbs.)	Shank Style	Cone Point Part Number	Chisel Part Number
HH300	23.5"	2.35"	22	6	ARH300-24CP	ARH300-24CH
HH500	23.5"	2.60"	26	6	ARH500-24CP	ARH500-24CH

We make bits for all Huskie Hammers - call for pricing.

## BITS TO FIT INDECO HAMMERS

Model Number	Overall Length	Approximate Body Diameter	Weight (lbs.)	Shank Style	Cone Point Part Number	Chisel Part Number
300 Series	23"	2.20"	21	5	AR6330-23CP	AR6330-23CH
553	28"	2.90"	41	5	AR6350-28CP	AR6350-28CH
600 Series	26"	3.10"	46	4	AR6360-26CP	AR6360-26CH

We make bits for all Indeco Hammers - call for pricing.

## BITS TO FIT NPK HAMMERS

Model Number	Overall Length	Approximate Body Diameter	Weight (lbs.)	Shank Style	Cone Point Part Number	Chisel Part Number
H3XA	28"	2.90"	40	6	AR6030-28CP	AR6030-28CH
H4XA	30"	3.52"	71	6	AR6040-30CP	AR6040-30CH
H6XA	36"	3.74"	110	6	AR6060-36CP	AR6060-36CH
H7XA	36"	4.10"	121	6	AR6070-36CP	AR6070-36CH

We make bits for all NPK Hammers - call for pricing.

All Demo bit chisels are Cross Cut unless specified as In-line.

To order 4 sided moil point for any hammer type - change 'CP' in above part numbers to 'MP'

WEST 800-858-8831

WWW.CHAMPIONCHISEL.COM

EAST 800-239-1434

## BOOM MOUNTED DEMOLITION BITS

### BITS TO FIT KENT HAMMERS

Model Number	Overall Length	Approximate Body Diameter	Weight (lbs.)	Shank Style	Cone Point Part Number	Chisel Part Number
KB-999	30"	3.50"	75	1	AR2000-30CP	AR2000-30CH
KB-999	36"	3.50"	90	1	AR2000-36CP	AR2000-36CH
KHB-200	24"	2.70"	41	1	AR2220-24CP	AR2220-24CH
KHB-3G	22"	2.35"	28	1	AR2230-22CP	AR2230-22CH
KHB-5G	28"	3.50"	45	4	AR2250-28CP	AR2250-28CH
KHB-8G	30"	3.50"	75	4	AR2280-30CP	AR2280-30CH
KF3	21"	2.00"	18	1	AR2KF30-21CP	AR2KF30-21CH
KF4	22"	2.35"	25	1	AR2KF40-22CP	AR2KF40-22CH
KF5	25"	2.60"	37	1	AR2KF50-25CP	AR2KF50-25CH
KF6	28"	2.90"	44	7	AR2KF60-28CP	AR2KF60-28CH
KF9	32"	3.50"	73	7	AR2KF90-32CP	AR2KF90-32CH

We make bits for all Kent Hammers - call for pricing.

### BITS TO FIT ATLAS-COPCO HAMMERS

Model Number	Overall Length	Approximate Body Diameter	Weight (lbs.)	Shank Style	Cone Point Part Number	Chisel Part Number
SBC-410	24"	2.56"	29	4	AR4100-24CP	AR4100-24CH
SBC-610	31"	3.15"	57	4	AR6100-31CP	AR6100-31CH

We make bits for all Atlas-Copco Hammers - call for pricing.

### BITS TO FIT RAMMER HAMMERS

Model Number	Overall Length	Approximate Body Diameter	Weight (lbs.)	Shank Style	Cone Point Part Number	Chisel Part Number
S22	20"	2.00"	15	4	AR7022-20CP	AR7022-20CH
S24	29"	2.81"	46	1	AR7224-29CP	AR7224-29CH
S25	29"	2.74"	42	4	AR7025-29CP	AR7025-29CH
S25	33"	2.74"	48	4	AR7025-33CP	AR7025-33CH
S26	35"	3.50"	79	6	AR7026-35CP	AR7026-35CH
S27	34"	3.30"	84	4	AR7027-34CP	AR7027-34CH

We make bits for all Rammer Hammers - call for pricing.

### BITS TO FIT STANLEY HAMMERS

Model Number	Overall Length	Approximate Body Diameter	Weight (lbs.)	Shank Style	Cone Point Part Number	Chisel Part Number
MB250/350	22"	2.50"	27	1	AR2500-22CP	AR2500-22CH
MB550	28"	2.75"	44	1	AR2550-28CP	AR2550-28CH

We make bits for all Stanley Hammers - call for pricing.

### BITS TO FIT TELEDYNE/TOKU HAMMERS

Model Number	Overall Length	Approximate Body Diameter	Weight (lbs.)	Shank Style	Cone Point Part Number	Chisel Part Number
TB220	30"	2.95"	44	7	AR5120-30CP	AR5120-30CH
TB400	32"	3.74"	88	7	AR5140-32CP	AR5140-32CH
TB700/725/750/825	36"	4.53"	157	7	AR5170-36CP	AR5170-36CH

We make bits for all Teledyne/Toku Hammers - call for pricing.

### BITS TO FIT TRAMAC HAMMERS

Model Number	Overall Length	Approximate Body Diameter	Weight (lbs.)	Shank Style	Cone Point Part Number	Chisel Part Number
BRH75/90	23"	2.35"	24	7	AR1690-23CP	AR1690-23CH
BRH125	26"	3.14"	45	7	AR1700-26CP	AR1700-26CH
BRH250/400	34"	3.72"	95	4	AR1800-34CP	AR1800-34CH
BRH501	39"	4.50"	159	4	AR1900-39CP	AR1900-39CH
BRP60/70	21"	1.92"	15	1	AR1660-21CP	AR1660-21CH
BRP85/95/100	24"	2.42"	26	4	AR1610-24CP	AR1610-24CH
BRP130/140/150	25"	2.90"	40	4	AR1613-25CP	AR1613-25CH
BRP130/140/150	30"	2.90"	48	4	AR1613-30CP	AR1613-30CH

We make bits for all Tramac Hammers - call for pricing.

All Demo bit chisels are Cross Cut unless specified as In-line.

To order 4 sided moil point for any hammer type - change 'CP' in above part numbers to 'MP'

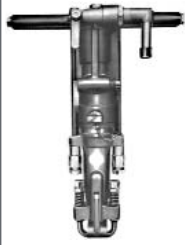

# DRILL STEEL AND ROCK BITS



Please call for current pricing.

## H THREAD DRILL STEEL



7/8" x 3-1/4" SHANK			7/8" x 4-1/4" SHANK			1" x 4-1/4" SHANK		
U.C. Length	Part Number	Unit Price	U.C. Length	Part Number	Unit Price	U.C. Length	Part Number	Unit Price
12"	DSHI0112		12"	DSH11112		12"	DSHI0212	
18"	DSHI0118		18"	DSH11118		18"	DSHI0218	
24"	DSHI0124		24"	DSH11124		24"	DSHI0224	
30"	DSHI0130	Please call for current pricing.	30"	DSH11130	Please call for current pricing.	30"	DSHI0230	Please call for current pricing.
36"	DSHI0136		36"	DSH11136		36"	DSHI0236	
48"	DSHI0148		48"	DSH11148		48"	DSHI0248	
60"	DSHI0160		60"	DSH11160		60"	DSHI0260	
72"	DSHI0172		72"	DSH11172		72"	DSHI0272	
96"	DSHI0196		96"	DSH11196		96"	DSHI0296	
120"	DSHI01120		120"	DSH111120		120"	DSHI02120	

\*Extensions available for Rope, D, E and H Thread.

## 11 DEGREE TAPERED DRILL STEEL



7/8" x 3-1/4" SHANK			7/8" x 4-1/4" SHANK			1" x 4-1/4" SHANK		
U.C. Length	Part Number	Unit Price	U.C. Length	Part Number	Unit Price	U.C. Length	Part Number	Unit Price
12"	DSIIT0112		12"	DSIIT11112		12"	DSIIT0212	
18"	DSIIT0118		18"	DSIIT11118		18"	DSIIT0218	
24"	DSIIT0124		24"	DSIIT11124		24"	DSIIT0224	
30"	DSIIT0130	Please call for current pricing.	30"	DSIIT11130	Please call for current pricing.	30"	DSIIT0230	Please call for current pricing.
36"	DSIIT0136		36"	DSIIT11136		36"	DSIIT0236	
48"	DSIIT0148		48"	DSIIT11148		48"	DSIIT0248	
60"	DSIIT0160		60"	DSIIT11160		60"	DSIIT0260	
72"	DSIIT0172		72"	DSIIT11172		72"	DSIIT0272	
96"	DSIIT0196		96"	DSIIT11196		96"	DSIIT0296	
120"	DSIIT01120		120"	DSIIT111120		120"	DSIIT02120	

\*Call for Rope, D or E Thread.

## DRILL STEEL ACCESSORIES

Part Number	Description	Unit Price
DS2H-D	H to D thread adapter	Please call for current pricing.
DSCH	H thread coupler	

## HEAVY DUTY CARBIDE ROCK BITS

Size	H Thread Part Number	Unit Price	11 Degree Tapered Part Number	Unit Price
1-1/8"	N/A		RB11T1-18	
1-1/4"	N/A		RB11T1-14	
1-3/8"	RBH1-38	Please call for current pricing.	RB11T1-38	Please call for current pricing.
1-1/2"	RBH1-12		RB11T1-12	
1-5/8"	RBH1-58		RB11T1-58	
1-3/4"	RBH1-34		RB11T1-34	
1-7/8"	RBH1-78		RB11T1-78	
2"	RBH2		RB11T2	
2-1/4"	RBH2-14		RB11T2-14	
2-1/2"	RBH2-12		N/A	
2-3/4"	RBH2-34		N/A	
3"	RBH3		N/A	



## ALL STEEL ROCK BITS

Size	H Thread Part Number	Unit Price
1-3/8"	RBSH1-38	Please call for current pricing.
1-1/2"	RBSH1-12	
1-5/8"	RBSH1-58	
1-3/4"	RBSH1-34	
1-7/8"	RBSH1-78	
2"	RBSH2	
2-1/8"	RBSH2-18	
2-1/4"	RBSH2-14	
2-1/2"	RBSH2-12	
2-5/8"	RBSH2-58	



# WHIRLEY BITS



Please call for current pricing.



7/8" X 3 1/4"	7/8" X 4 1/4"	1" X 4 1/4"	C-9 CLASS* 3/4" RND X 3-1/4"
---------------	---------------	-------------	---------------------------------

U.C. Length	Part Number	Unit Price	U.C. Length	Part Number	Unit Price	U.C. Length	Part Number	Unit Price	U.C. Length	Part Number	Unit Price
1/2"									8"	WBCP908-12	
									12"	WBCP912-12	
									18"	WBCP918-12	
5/8"	9" WBI019-58 14" WBI0114-58 20" WBI0120-58 24" WBI0124-58		9"	WBI119-58 14" WBI1114-58 20" WBI1120-58 24" WBI1124-58					8"	WBCP908-58	
									12"	WBCP912-58	
									18"	WBCP918-58	
3/4"	9" WBI019-34 14" WBI0114-34 20" WBI0120-34 24" WBI0124-34 28" WBI0128-34		9"	WBI119-34 14" WBI1114-34 20" WBI1120-34 24" WBI1124-34 28" WBI1128-34 36" WBI1136-34					8"	WBCP908-34	
									12"	WBCP912-34	
									18"	WBCP918-34	
7/8"	9" WBI019-78 14" WBI0114-78 20" WBI0120-78 24" WBI0124-78 28" WBI0128-78		9"	WBI119-78 14" WBI1114-78 20" WBI1120-78 24" WBI1124-78 28" WBI1128-78					8"	WBCP908-78	
									12"	WBCP912-78	
									18"	WBCP918-78	
1"	9" WBI019-1 14" WBI0114-1 20" WBI0120-1 24" WBI0124-1 28" WBI0128-1		9"	WBI119-1 14" WBI1114-1 20" WBI1120-1 24" WBI1124-1 28" WBI1128-1		24"	WBI0224-1		8"	WBCP908-1	
									12"	WBCP912-1	
									18"	WBCP918-1	
									24"	WBCP924-1	
1-1/8"	14" WBI0114-118 20" WBI0120-118 24" WBI0124-118 28" WBI0128-118 36" WBI0136-118		14"	WBI114-118 20" WBI1120-118 24" WBI1124-118 28" WBI1128-118 36" WBI1136-118		14"	WBI0214-118		8"	WBCP908-118	
						20"	WBI0220-118		12"	WBCP912-118	
						24"	WBI0224-118		18"	WBCP918-118	
						28"	WBI0228-118		24"	WBCP924-118	
1-1/4"	14" WBI0114-114 20" WBI0120-114 24" WBI0124-114 28" WBI0128-114		14"	WBI114-114 20" WBI1120-114 24" WBI1124-114 28" WBI1128-114		14"	WBI0214-114		8"	WBCP908-114	
						20"	WBI0220-114		12"	WBCP912-114	
						24"	WBI0224-114		18"	WBCP918-114	
						28"	WBI0228-114		24"	WBCP924-114	
1-3/8"	14" WBI0114-138 20" WBI0120-138 24" WBI0124-138 28" WBI0128-138		14"	WBI114-138 20" WBI1120-138 24" WBI1124-138 28" WBI1128-138		14"	WBI0214-138		12"	WBCP912-138	
1-1/2"	14" WBI0114-112 20" WBI0120-112 24" WBI0124-112 28" WBI0128-112		14"	WBI114-112 20" WBI1120-112 24" WBI1124-112 28" WBI1128-112		14"	WBI0214-112				
						20"	WBI0220-112				
						24"	WBI0224-112				
						28"	WBI0228-112				
						48"	WBI0248-112				

\*4 spline whirley bit - also called C-9 Sparta, CP-9A, MRD-9, 5-LHD  
Bit size & length can be made if not listed. Call for pricing.

**A**

# AIR TOOL ACCESSORIES

**A**

Class A Pricing

## CHIPPER RETAINERS & ACCESSORIES



Lock Spring



Solid Retainer



Quick Change Retainer

Part Number	Type	Unit Price
CHR-1190CP	Solid/Taper/Oval	49.11
CHR-1190RCP	Solid/Taper/Round	51.11
CHR-1190IR	Solid/Taper/Oval	49.11
CHR-1190RIR	Solid/Taper/Round	51.11
CHR-1190SUL	Solid/Taper/Oval	49.11
CHR-1190RSUL	Solid/Taper/Round	51.11
CHR-11901655	Solid/Straight/Oval	51.83
CHR-1190R1655	Solid/Straight/Round	51.11
CHR-1190APT	Solid/Straight/Oval	49.11
CHR-1190RAPT	Solid/Straight/Round	51.11
CHR-Spring	Fits all	4.10

Part Number	Type	Unit Price
CHR-1291CP	Quick Change/Taper	125.00
CHR-1291IR	Quick Change/Taper	125.00
CHR-1291SUL	Quick Change/Taper	125.00
CHR-1291APT	Quick Change/Straight	125.00
CHR-1291HATCO	Quick Change/Threaded	125.00
CHR-1293IR	Quick Change/Threaded	125.00

## AIR INLET HOSES, SWIVELS & OILERS



Air Inlet Hose Swivel

Part Number	Description	Unit Price
HS-782412	7/8"-24UNC x 1/2" Hose Barb (most chippers)	32.44
HS-1212	1/2"NPT x 1/2" Hose Barb (most busters)	34.44
HS-3812	3/8"NPT x 1/2" Hose Barb (busters & chippers)	38.44

\* Champion Chisel chipper hammers come with 7/8" standard air inlet bushing.  
 \* If using 3/8" hose swivel - must convert chipping hammer air inlet bushing to 3/8".



In Line Oiler

Description	Small	Medium	Large
Oil Capacity	1.4 oz	3.7 oz	11 oz
Pipe Size	1/2"	3/4"	3/4"
Max. Working Pressure	500 psi	260 psi	300 psi
Dimensions	4-1/2"x2-1/4"	6" x 2-3/4"	7"x3-1/2"
Weight	.875 lbs	1.5 lbs	2 lbs
Part Number	ILO-S	ILO-M	ILO-L
Unit Price	61.43	70.41	86.88



Whip Hose Assembly

Part Number	Description	Unit Price
WHA-6CH	6' whip hose assembly with HS-782412 swivel, coupling, and ILO-S in line oiler.	119.80

(A)

# AIR TOOL ACCESSORIES

(A)

Class A Pricing

## JUMBO RIVET BUSTER ACCESSORIES



Retainer

Part Number	Fits Tool	I.D.	Unit Price
RBR-21902557	CP-4181	2.557"	104.08
RBR-21902565	JET RB11	2.565"	104.08
RBR-21902400	JET RB90, RB91	2.400"	104.08
RBR-21902445	CP-60, 80, 90	2.445"	104.08
RBR-1851	APT133/MP1133	2.610"	118.34
RBR-9001200	IR9001	Threaded	124.33
RBC-9RB-207	Clip for RBR-9001200		49.43

Part Number	Description	Unit Price
RBP-RB2104	Rubber Bumper	3.90
RBP-PB2104	Poly Bumper	7.86
RBP-US2101	Upper Sleeve	13.93
RBP-LS2103	Lower Sleeve	14.44
RBP-LS2103S	Split Lower Sleeve	17.04
RBP-RS2194	Retainer Spring	3.44



Lower Sleeve



Upper Sleeve



Split Lower Sleeve



Rubber Bumper



Retainer Spring

## .401 & .498 SHANK TOOL ACCESSORIES

Part Number	Description	Unit Price
ZGP-BHS-401	Beehive	7.11
ZGP-BHS-498	Beehive	10.42
ZGP-QCS-401	Quick Change Spring	7.00
ZGP-QCS-498	Quick Change Spring	10.42
ZGP-QCR-401	Quick Change Ball Type For 401 Turn Type Chisels	46.87
ZGP-QCR-498	Quick Change Ball Type For 498 Turn Type Chisels	104.49
ZGP-QCR-NT	Quick Change Ball Type For 401 & 498 Non-Turn Type Chisels	76.86



Beehive Spring



Quick Change Spring



Quick Change Ball Type





# SHIPPING WEIGHTS

Pneumatic Zip Gun Bits 401 & 498 Turn Type		Pneumatic Weld Flux Bits Cleco Style		Drill Steel 11 Degree Tapered		Rock Bits 11 Degree Tapered		Whirley Bits 7/8" x 4 1/4"		
Part Number	Weight (lbs.)	Part Number	Weight (lbs.)	Part Number	Weight (lbs.)	Part Number	Weight (lbs.)	Part Number	Weight (lbs.)	
ZGPTT40107	.33	SC20024-20	1.63	DS11T10112	3	RB11T1-58	.75	WB11120-78	3.5	
ZGPTT40110	.51	SC20007-30	.8	DS11T10118	4	RB11T1-34	1	WB11124-78	4.25	
ZGPTT40114	.73	SBC20007-14	.4	DS11T10124	5	RB11T1-78	1	WB11128-78	5	
ZGBT40107	.37	SBC20012-14	.7	DS11T10130	6	RB11T2	1	WB1119-1	2	
ZGBT40112	.5	SBC20018-14	1.2	DS11T10136	7	RB11T2-14	2	WB11114-1	2.5	
ZGBT40124	1	SBC20007-20	.5	DS11T10148	9	Rock Bits Accessories				
ZGCTT40107	.36	SBC20007-30	.8	DS11T10160	11					
ZGCTT40110	.54	Pneumatic Weld Flux Bits Ingersoll Rand Style		DS11T10172	14	Part Number		Weight (lbs.)	WB11120-1	3.5
ZGCTT40112	.65	Part Number	Weight (lbs.)	DS11T10196	18	DS2HD	.63	WB11124-1	4.5	
ZGCTT40118	1	SP10007	.4	DS11T101120	22	DSCH	.31	WB11128-1	5.25	
ZGTPPT40105	.2	SP10012	.7	DS11T11112	3.25	Whirley Bits 7/8" x 3 1/4"				
ZGTPPT40107	.2	SP10018	1.2	DS11T11118	4.25	Part Number	Weight (lbs.)	WB11114-118	2.75	
ZGCTT49807	.52	SP10018	1.2	DS11T11124	5.25	WB11120-118	3.75	WB11120-118	4.75	
ZGCTT49812	.8	SB10007	.4	DS11T11130	6.25	WB11124-118	4.75	WB11128-118	5.5	
ZGCTT49818	1.45	SB10012	.7	DS11T11136	7.25	WB11114-114	2.75	WB11120-114	3.75	
ZGTPPT49807	.6	SB10018	1.2	DS11T11148	9.25	WB11124-114	4.75	WB11128-114	5.5	
Pneumatic Zip Gun Bits 401 & 498 Non-Turn Type		SC10007	.4	DS11T11160	11.25	WB1019-58	2	WB11114-138	3	
Part Number	Weight (lbs.)	SC10012	.7	DS11T11172	14.25	WB10114-58	2.5	WB11120-138	4	
ZGCNT40107	.46	SC10018	1.2	DS11T11196	18.25	WB10120-58	3.5	WB11124-138	5	
ZGCNT40110	.70	SC10024	1.4	DS11T11120	22.25	WB10128-58	4.5	WB11128-138	5.75	
ZGCNT40112	.88	SC10030	1.8	DS11T10212	4	WB1019-34	2	WB11114-112	2.75	
ZGCNT40118	1.4	SC10007-14	.4	DS11T10218	5	WB10114-34	2.5	WB11120-112	3.75	
ZGBCNT40107-125	.52	SC10012-14	.7	DS11T10224	7	WB10120-34	3.5	WB11124-112	4.75	
ZGBCNT40110-125	.75	SC10018-14	1.2	DS11T10230	8	WB10128-34	5	WB11128-112	5.5	
ZGBCNT40118-125	1.4	SC10007-20	.5	DS11T10236	10	WB1019-78	2	Whirley Bits 1" x 4 1/4"		
ZGCNT49807	.4	SC10007-30	.8	DS11T10248	12	WB10114-78	2.5	Part Number	Weight (lbs.)	
ZGCNT49812	.8	SBC10007-14	.4	DS11T10260	14	WB10120-78	3.5	WB10224-1	4.75	
ZGCNT49818	1.4	SBC10012-14	.7	DS11T10272	18	WB10124-78	4.25	WB10214-118	3	
ZGBCNT49807-125	.95	SBC10018-14	1.2	DS11T10296	23	WB10128-78	5	WB10220-118	4	
ZGBCNT49812-125	.95	SBC10024-14	1.4	DS11T102120	24	WB1019-1	2	WB10224-118	5	
Pneumatic Zip Gun Bits .371 & .432 Style		SBC10007-20	.5	Rock Bits H Thread - Heavy Duty		WB10114-1	2.5	WB10228-118	5.75	
Part Number	Weight (lbs.)	SBC10007-30	.8	Part Number	Weight (lbs.)	WB10120-1	3.5	WB10214-114	3	
SC37108	.2	Drill Steel H Thread		RBH1-38	.5	WB10124-1	4.5	WB10220-114	4	
SC37112	.6	Part Number	Weight (lbs.)	RBH1-12	.5	WB10128-1	5.25	WB10224-114	5	
SC37118	.9	DSH10112	3	RBH1-58	.5	WB10114-118	2.75	WB10228-114	5.75	
SC43208	.2	DSH10118	4	RBH1-34	.75	WB10120-118	3.75	WB10214-138	3.25	
SC43212	.6	DSH10124	5	RBH1-78	.75	WB10124-118	4.75	WB10220-138	4.25	
SC43218	.9	DSH10130	6	RBH2	1	WB10128-118	5.5	WB10224-138	5.25	
Pneumatic Weld Flux Bits Cleco Style		DSH10136	7	RBH2-14	1	WB10114-114	2.75	WB10228-138	6	
Part Number	Weight (lbs.)	DSH10148	9	RBH2-12	1	WB10120-114	3.75	WB10214-112	3.25	
SP20007	.4	DSH10160	11	RBH2-34	1.7	WB10124-114	4.75	WB10220-112	4.25	
SP20009	.54	DSH10172	13	RBH3	2	WB10128-114	5.5	WB10224-112	5.25	
SP20012	.7	DSH10196	17	Rock Bits H Thread - All Steel		WB10114-138	3	WB10228-112	6	
SP20018	1.2	DSH101120	21	Part Number	Weight (lbs.)	WB10120-138	4	WB10214-112	3.25	
SB20007	.4	DSH11112	3	RBSH1-38	.31	WB10124-138	5	WB10220-112	4.25	
SB20012	.7	DSH11118	4	RBSH1-12	.38	WB10128-138	5.75	WB10224-112	5.25	
SB20018	1.2	DSH11124	5	RBSH1-58	.44	WB10114-112	2.75	WB10120-112	3.75	
SC20007	.4	DSH11130	6	RBSH1-34	.5	WB10124-112	4.75	WB10128-112	5.5	
SC20009	.54	DSH11136	7	RBSH1-78	.5	Whirley Bits 7/8" x 4 1/4"				
SC20012	.7	DSH11148	9	RBSH2	.56	Part Number	Weight (lbs.)	WB1119-58	2	
SC20018	1.2	DSH11160	11	RBSH2-14	.63	WB11114-58	2.5	WB11120-58	3.5	
SC20024	.6	DSH11172	13	RBSH2-12	1.06	WB1119-34	2	WB11114-34	2.5	
SC20007-14	.4	DSH11196	17	RBSH2-58	1.25	WB11120-34	3.5	WB11124-34	4.5	
SC20012-14	.7	DSH111120	21	Rock Bits 11 Degree Tapered		WB11128-34	5	WB1119-78	2	
SC20018-14	1.2	DSH10212	4	Part Number	Weight (lbs.)	WB11114-78	2.5			
SC20007-20	.5	DSH10218	5	RB11T1-18	.5					
SC20018-20	1.22	DSH10224	7	RB11T1-14	.5					
		DSH10230	8	RB11T1-38	.5					
		DSH10236	9	RB11T1-12	.75					
		DSH10248	12							
		DSH10260	14							
		DSH10272	18							
		DSH10296	22							
		DSH102120	27							

# Box Quantity Guidelines

Box quantities listed below are for the most frequently shipped items. This is only a partial listing of the products offered by Champion Chisel - please call factory for box quantity information for parts not listed below.

Pneumatic Chipper Steel Round Collar/.580 Hex (pages 6-7)		Pneumatic Chipper Steel Oval Collar/.680 Round (pages 8-9)		Pavement Breaker Steel 1 1/8" x 6" Shank (pages 11-12)		Electric Chipper Steel 3/4" Hex Demo (page 13)		Electric Chipper Steel SDS Plus (page 14)	
Part Number	Box Qty	Part Number	Box Qty	Part Number	Box Qty	Part Number	Box Qty	Part Number	Box Qty
P5809RC	25	C6818OC	20	PD1031	5	FSST-DEMO	20	PP10	30
P5812RC	25	C6809OC-20	25	PD103114	5	DC12-45	15	PC10	30
P5818RC	20	C6812OC-20	20	PD103112	5	DC18-45	15	PC07-30	20
C5809RC	25	C6818OC-20	20	PD103134	5	DCB12-30	20	PCB07-30	20
C5812RC	25	C6809OC-30	25	PD1032	5	GD34-DEMO	15	<b>Electric Chipper Steel Makita 8900N (page 15)</b>	
C5818RC	20	C6812OC-30	20	GD10358	5	<b>Electric Chipper Steel Spline Drive (page 13)</b>		<b>Part Number</b>	<b>Box Qty</b>
C5809RC-20	25	C6818OC-30	15	GD10334	5	<b>Part Number</b>	<b>Box Qty</b>	HP15	10
C5812RC-20	20	BH1-680OC	5	GD10378	5	RP12	25	HC15	10
C5818RC-20	20	CS-680OC	5	GD1031	5	RP18	20	HC16-30	10
C5809RC-30	25	FS-2MML	5	PDR103-112	2	RC12	25	BH1-MAKITA	5
C5812RC-30	20	FSS680OC	20	PDR103-2	2	RC18	20	CS-MAKITA	5
C5818RC-30	15	GD68OC34	15	<b>Pavement Breaker Steel 1 1/4" x 6" Shank (pages 11-12)</b>		RC12-20	20	<b>Electric Chipper Steel Wacker 3/4" x 3-1/4" (page 15)</b>	
BH1-580RC	5	<b>Pavement Breaker Steel 7/8" x 3 1/4" Shank (page 10)</b>		<b>Part Number</b>	<b>Box Qty</b>	RC18-20	20	<b>Part Number</b>	<b>Box Qty</b>
FS-2MML	5	<b>Part Number</b>	<b>Box Qty</b>	PI0414	5	RC12-30	20	WP12	10
FSS580RC	20	PI0114	5	PI0418	5	RC18-30	20	WC12	10
GD58RC34	15	PI0118	5	CI0414	5	BH1-ROTARY	15	WC12-30	10
<b>Pneumatic Chipper Steel Round Collar/.680 Round (pages 6-7)</b>		CI0114	5	CI0418	5	AC-ROTARY	5	<b>Electric Chipper Steel 1-1/8" Hex/Notch (page 15)</b>	
<b>Part Number</b>	<b>Box Qty</b>	CI0118	5	CCI1414	5	CS-ROTARY	5	<b>Part Number</b>	<b>Box Qty</b>
P6809RC	25	CC11114	5	CCI1418	5	FS-2MML	5	WP12	10
P6812RC	25	CC11118	5	AC104	5	FSS-ROTARY	20	WC12	10
P6818RC	20	AC101	5	CS104	5	FSST-ROTARY	20	WC12-30	10
C6809RC	25	CS101	5	BH104	5	RC12-45	15	<b>Electric Chipper Steel 1-1/8" Hex/Notch (page 15)</b>	
C6812RC	25	BH101	5	PD10458	5	RC18-45	15	<b>Part Number</b>	<b>Box Qty</b>
C6818RC	20	<b>Pavement Breaker Steel 1" x 4 1/4" Shank (pages 10 &amp; 12)</b>		PD10434	5	RCB12-30	20	PI0314-B	10
C6809RC-20	25	<b>Part Number</b>	<b>Box Qty</b>	PD10478	5	GD34-ROTARY	15	PI0318-B	10
C6812RC-20	20	PI0214	5	PD1041	5	<b>Electric Chipper Steel SDS Max (page 13)</b>		CI0314-B	10
C6818RC-20	20	PI0218	5	PD104114	5	<b>Part Number</b>	<b>Box Qty</b>	CI0318-B	10
C6809RC-30	25	CI0214	5	PD104112	5	MP12	25	CC11314-B	10
C6812RC-30	20	CI0218	5	PD104134	5	MC12	25	CC11318-B	10
C6818RC-30	15	CC11214	5	PD1042	5	MC12-20	20	BH103-B	5
BH1-680RC	5	CC11218	5	GD10458	5	MC12-30	20	AC103-B	5
CS-680RC	5	AC102	5	GD10434	5	BH1-MAX	15	CS103-B	5
FS-2MML	5	CS102	5	GD10478	5	AC-MAX	5	<b>Pneumatic Weld Flux Bits Cleco Style (page 19)</b>	
FSS680RC	20	BH102	5	GD1041	5	CS-MAX	5	<b>Part Number</b>	<b>Box Qty</b>
GD68RC34	15	PD10258	5	PDR104-112	5	FS-2MML	5	SP20007	50
<b>Pneumatic Chipper Steel Oval Collar/.580 Hex (pages 8-9)</b>		PD10234	5	PD104-2	5	FSS-MAX	20	SP20009	50
<b>Part Number</b>	<b>Box Qty</b>	PD10278	5	<b>Jumbo Rivet Buster Steel (page 12)</b>		MC12-45	15	SP20012	50
P5809OC	25	PD1021	5	<b>Part Number</b>	<b>Box Qty</b>	MCB12-20	20	SP20018	25
P5812OC	25	PD102114	5	JRBP10-86	25	GD34-MAX	15	SC20007	50
P5818OC	20	PD102112	5	JRBP12-86	25	<b>Electric Chipper Steel Kango 21mm (page 14)</b>		SC20009	50
C5809OC	25	PD102134	5	JRBP18-86	20	<b>Part Number</b>	<b>Box Qty</b>	SC20012	50
C5812OC	25	PD1022	5	JRBC10-86	25	KPI2	25	SC20018	25
C5818OC	20	GD10258	5	JRBC12-86	25	KPI8	20	SC20024	25
C5809OC-20	25	GD10234	5	JRBC18-86	20	KCI2	25	<b>Pneumatic Weld Flux Bits Ingersoll Rand Style (page 19)</b>	
C5812OC-20	20	GD10278	5	JRBR9-86	25	KCI8	20	<b>Part Number</b>	<b>Box Qty</b>
C5818OC-20	20	GD1021	5	<b>Electric Chipper Steel 3/4" Hex Demo (page 13)</b>		KCI2-20	20	SPI0007	50
C5809OC-30	25	<b>Pavement Breaker Steel 1 1/8" x 6" Shank (pages 11-12)</b>		<b>Part Number</b>	<b>Box Qty</b>	KCI8-20	20	SPI0012	50
C5812OC-30	20	<b>Part Number</b>	<b>Box Qty</b>	DP12	25	KCI2-30	20	SPI0018	25
C5818OC-30	15	PI0314	5	DC12	20	KCI8-30	20	SC10007	50
BH1-580OC	5	PI0318	5	DC20	20	BH1-KANGO	15	SC10012	50
FS-2MML	5	CI0314	5	DC12-20	20	AC-KANGO	5	SC10018	25
FSS580OC	20	CI0318	5	DC20-20	20	CS-KANGO	5	SC10024	25
GD58OC34	15	CC11314	5	DC12-30	20	FS-2MML	5	<b>Electric Chipper Steel 3/4" Hex Demo (page 13)</b>	
<b>Pneumatic Chipper Steel Oval Collar/.680 Round (pages 8-9)</b>		CC11318	5	DC20-30	20	KPI2	25	<b>Part Number</b>	<b>Box Qty</b>
<b>Part Number</b>	<b>Box Qty</b>	AC103	5	BH1-DEMO	15	KPI8	20	SPI0007	50
P6809OC	25	CS103	5	AC-DEMO	5	KCI2	25	SPI0012	50
P6812OC	25	BH103	5	CS-DEMO	5	KCI8	20	SPI0018	25
P6818OC	20	PD10358	5	FS-2MML	5	KCI2-20	20	SC10007	50
C6809OC	25	PD10334	5	FSS-DEMO	20	KCI8-20	20	SC10012	50
C6812OC	25	PD10378	5	FSST-DEMO	20	KCI2-30	20	SC10018	25
				FSST-DEMO	20	GD34-KANGO	15	SC10024	25